

Chemical and kinetic characterization of diffusional phase transformation

1. Fundamentals of diffusion processes
2. Impact of analytical electron microscopy in examination of diffusion processes
3. Diffusional phase transformations at migrating boundaries
 - a. Discontinuous precipitation (DP)
 - b. Discontinuous coarsening (DC)
 - c. Discontinuous dissolution (DD)
 - d. Diffusion induced grain boundary migration (DIGM)
 - e. Discontinuous ordering (DO)
4. Determination of grain boundary diffusivity



5. Determination of volume diffusion coefficient

a) Diffusion couple(Matano-Boltzman plane)

b) Grain boundary depletion

6. Determination of phase transformation type based on the microchemical analysis



Diffusion at stationary grain boundary

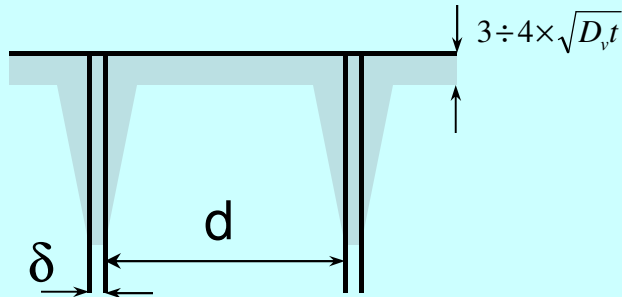

$$\sqrt{D_v t} \ll d$$

$$\sqrt{D_v t} \gg s \cdot \delta$$

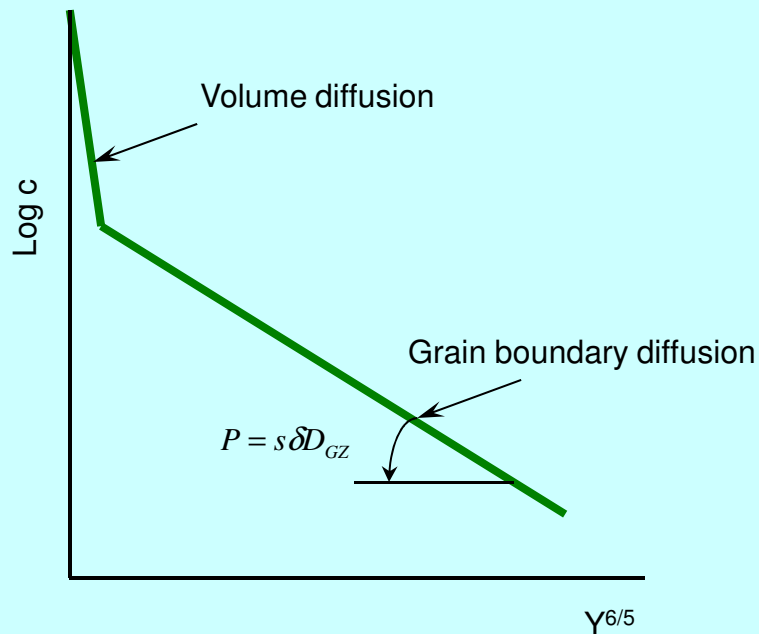

$$p = s \delta D_{GZ} = 1.322 \sqrt{\frac{D_v}{t}} \left(-\frac{\partial \log c}{\partial t^{6/5}} \right)^{-5/3}$$





DISCONTINUOUS REACTIONS

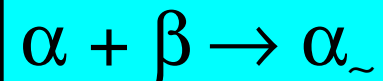
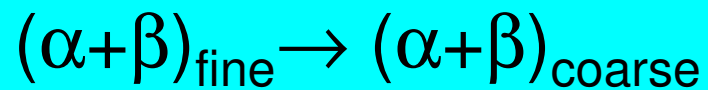
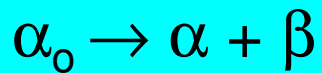
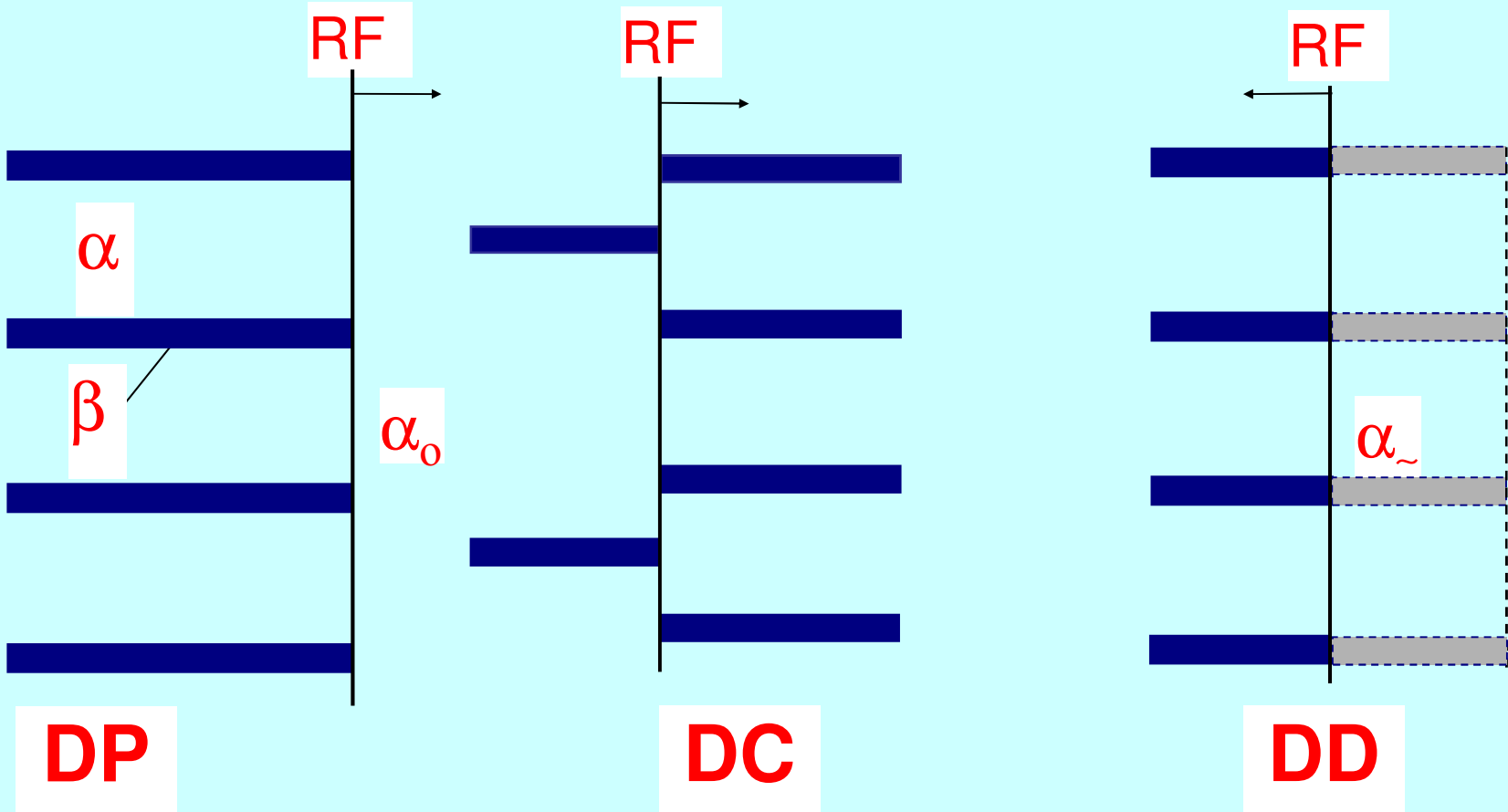

Impact of analytical electron microscopy in examination of diffusion processes

1. Fundamentals of AEM

2. Factors influencing the accuracy of microchemical analysis

a. Spatial resolution

b. Relationship between sample geometry, incident electron beam and location of EDX detector

c. Detectability limit

d. Signal deconvolution



Electron optical configuration in AEM

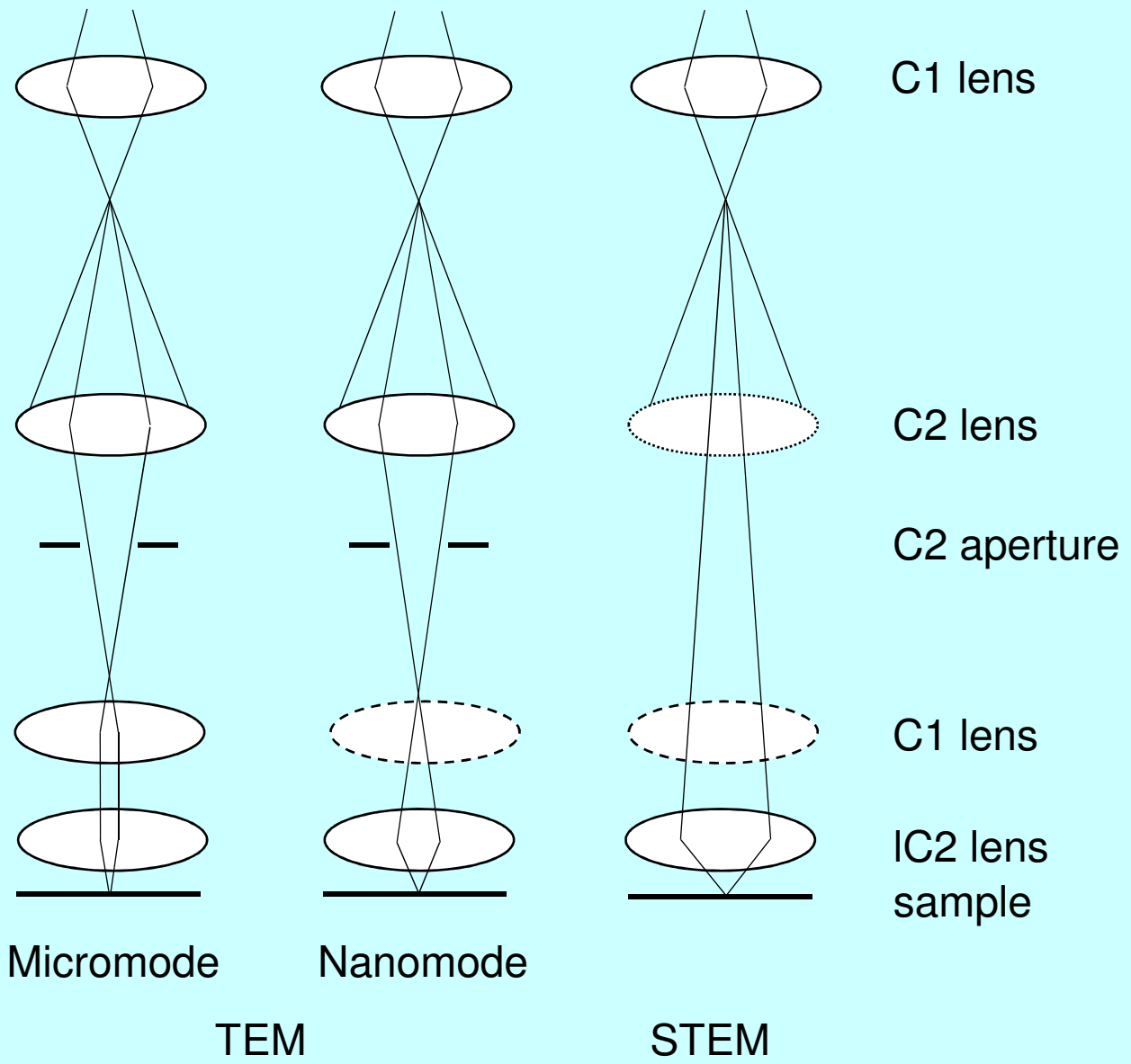

Principles of high resolution microchemical analysis

Activated volume of X-ray signal

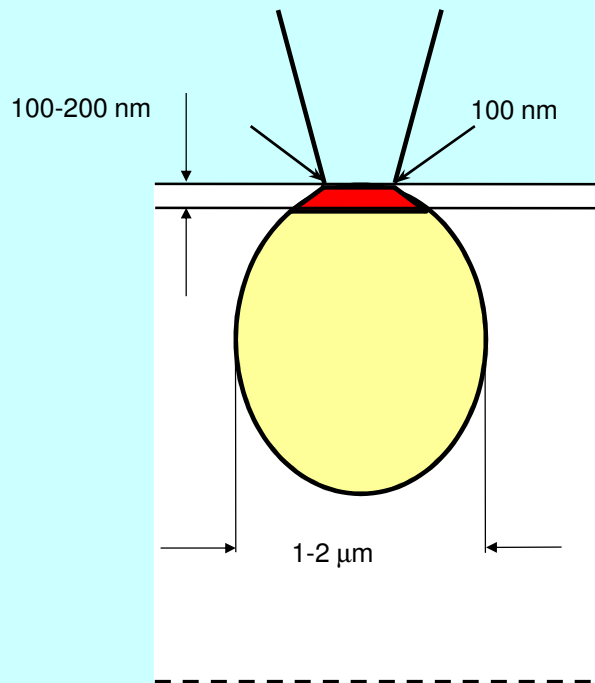

Bulk sample

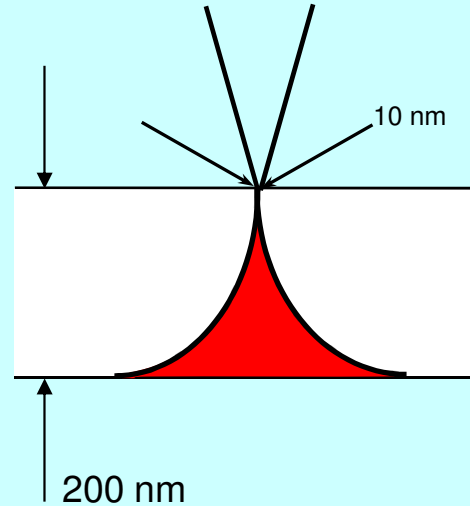

LaB₆

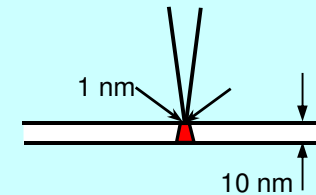

Field emission gun

AEM / EPMA

Activation volume: $\times 10^5 \downarrow$ Beam broadening: $\times 10^2 \downarrow$



EELS/EDX

Advantages:

Smaller beam broadening for thicker samples.

Detection of all the elements including He.

Superior energy resolution.

Disadvantages:

Need for the very thin sample (≤ 50 nm)

Much more complex quantification of the results.







Spatial resolution

measure of the smallest distance R between the centres of two analysed volumes from which independent X-ray microanalysis can be obtained

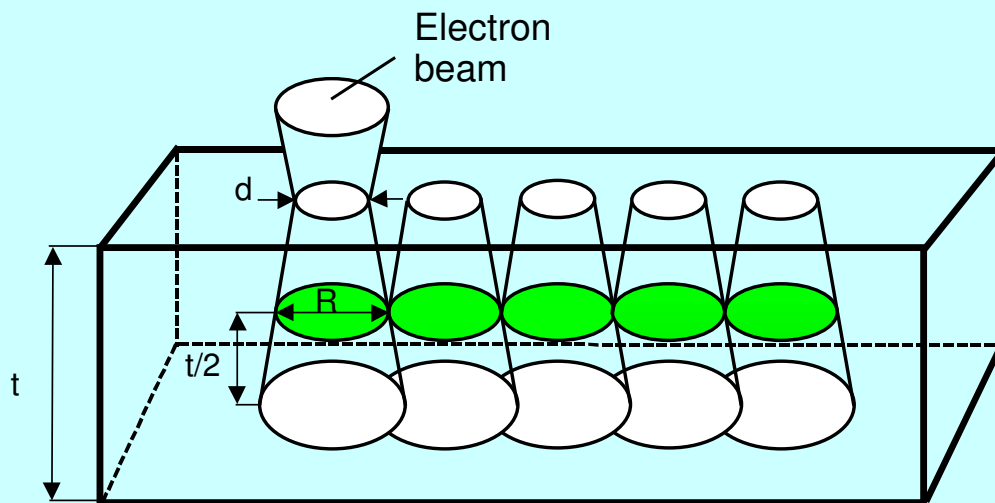

b - beam broadening in nm,
 d - incident electron beam diameter in nm,
 Z - atomic number,

A - atomic weight,
 E - beam energy in kV,
 ρ - specimen density in g/cm³,
 t - specimen thickness in cm.

$$R = \frac{d + \sqrt{d^2 + b^2}}{2}$$

$$b = 625 \frac{Z}{E_o} \left(\frac{\rho}{A} \right)^{0.5} t^{1.5}$$



Previous definition

Distance R assumed to be exit diameter of interaction volume

According to new definition more points can be obtained without loss of spatial resolution

D.B. Williams, J.R. Michael, J.I. Goldstein, A.D. Romig:

Ultramicroscopy 47 (1992) 121

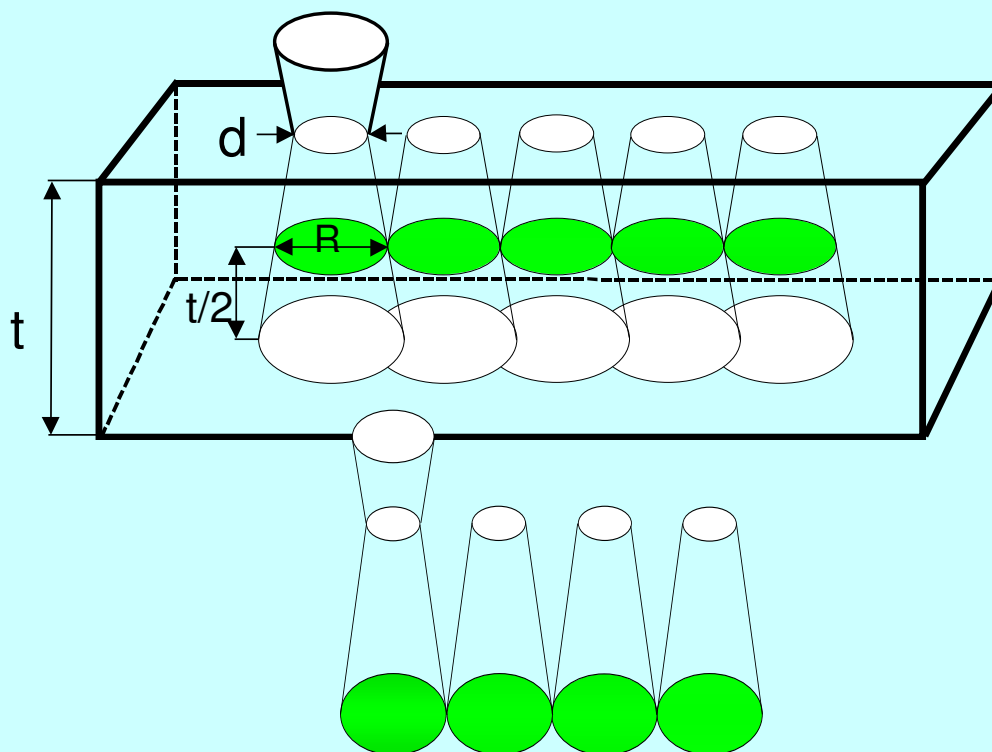





DP reaction

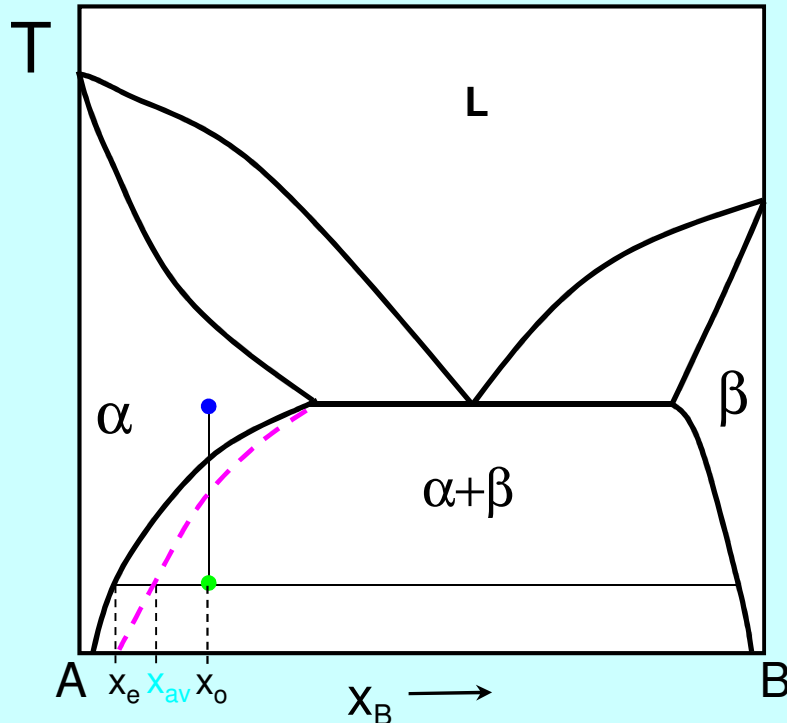

x_o - solute content in alloy
 x_e - equilibrium solute content at α/β interface
 x_{av} - average solute content in α lamella

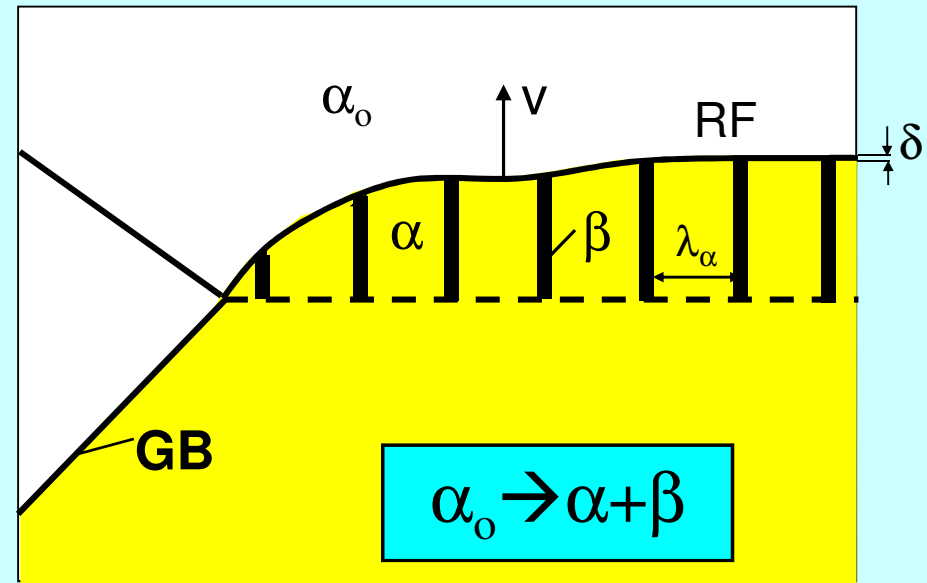

δ - width of reaction front (RF)
 λ_α - thickness of α lamella
 v - growth rate of discontinuous precipitates
GB- grain boundary; RF=GB

The solute redistribution occurs at the moving RF

There exists an excess of solute atoms within the α lamella compared to the equilibrium state



Relation between specimen geometry, incident electron beam and location of EDX detector

Analysis across RF

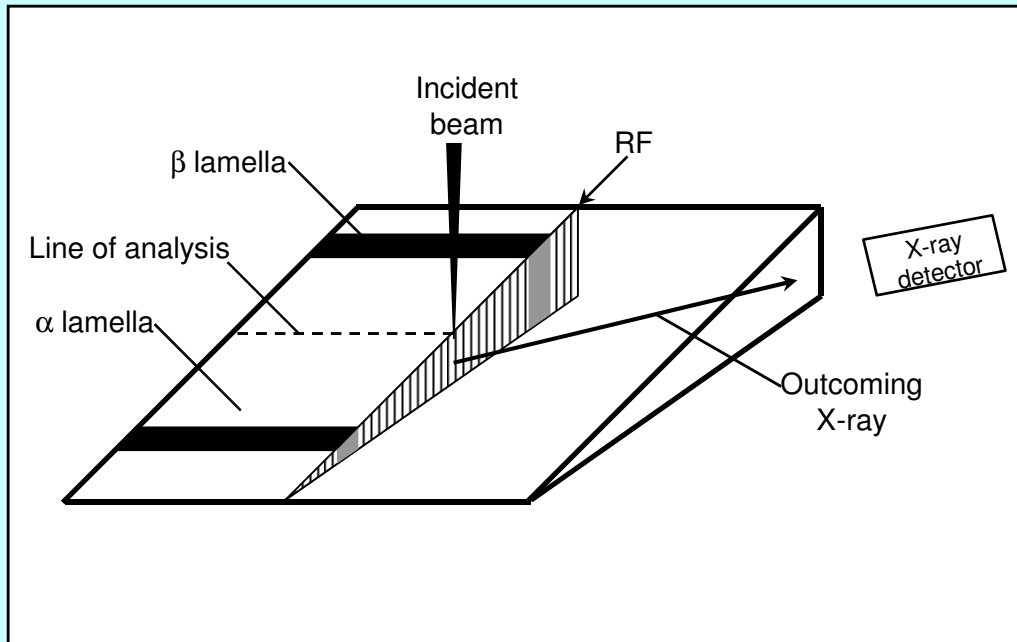

RF almost perpendicular to the foil surface so that it can be tilted parallel to the incident electron beam

RF situated in a direction perpendicular to the foil edge to enable measurement of the profile at the same foil thickness

EDX detector positioned parallel to the line of analysis, which assures the same absorption path length throughout the specimen as well as the resulting absorption correction



Solute distribution across reaction front

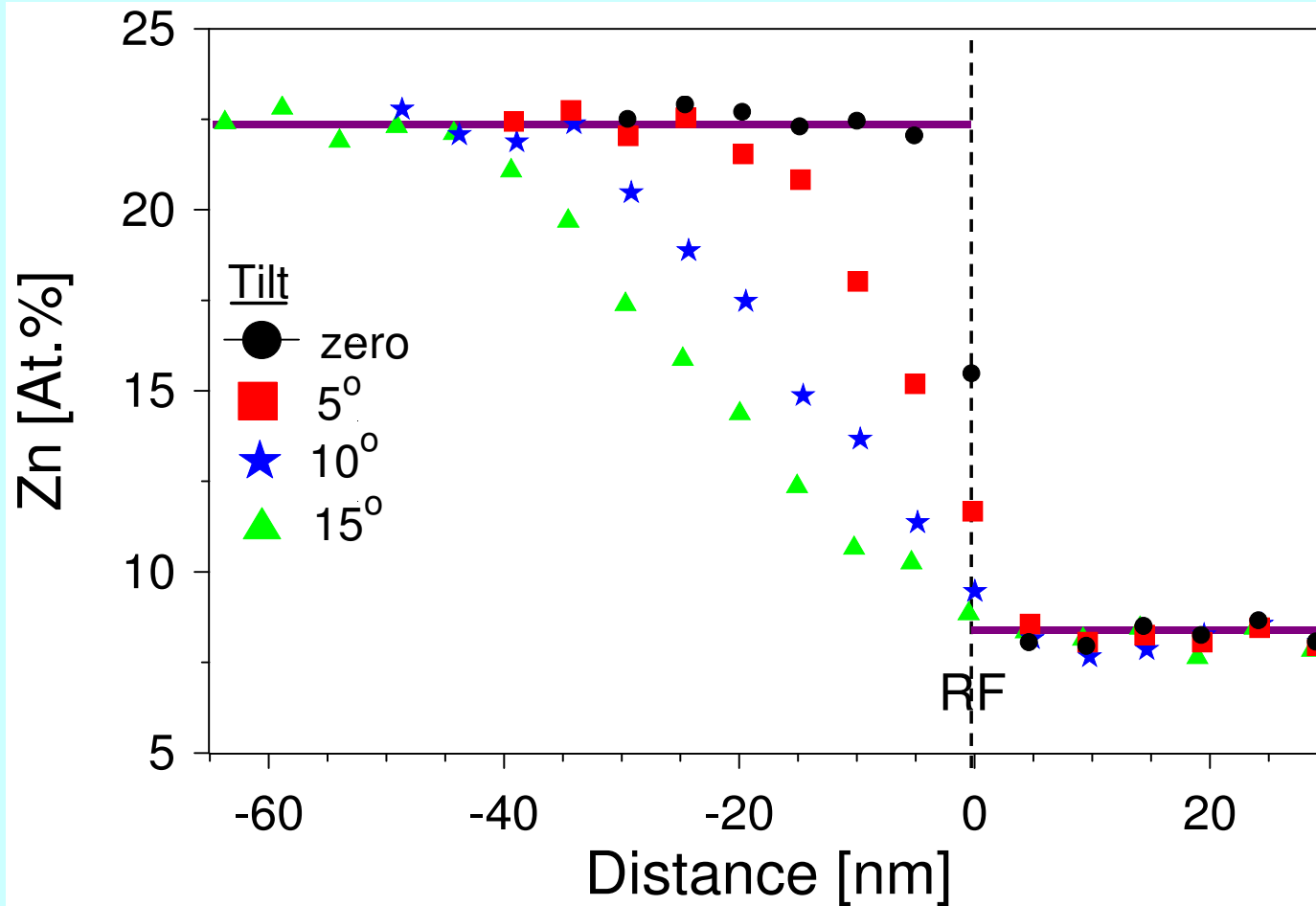



Analysis across α lamella

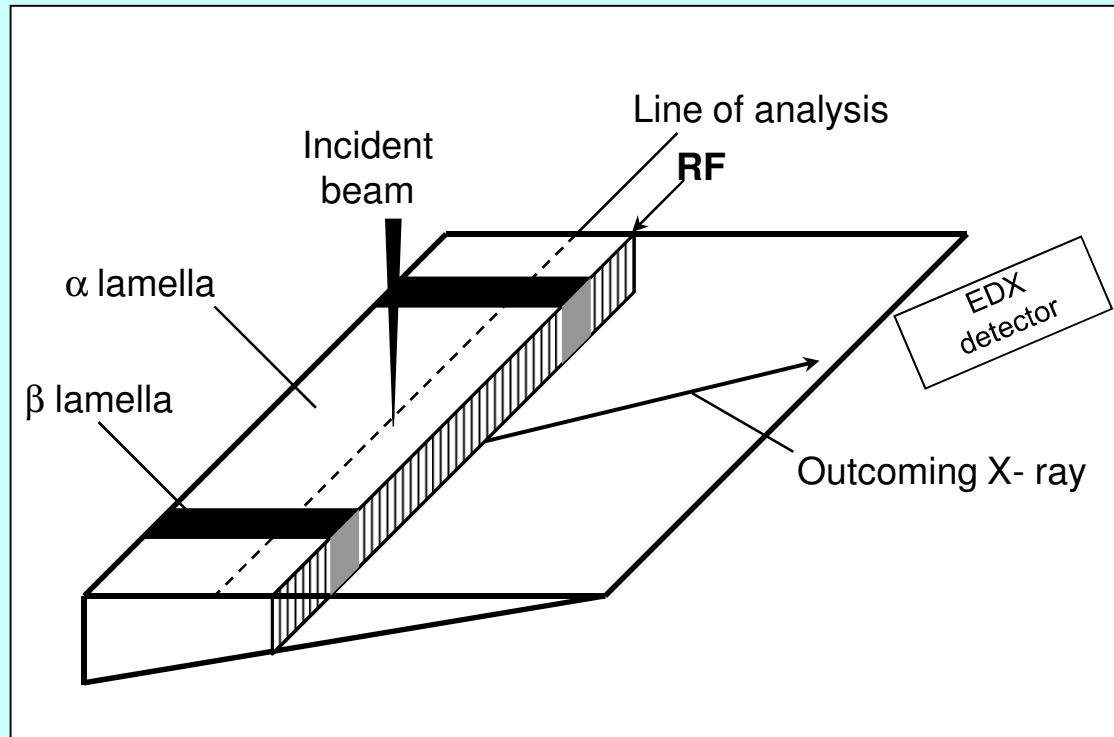

Incident electron beam and EDX detector parallel to the β lamellae

EDX detector perpendicular to the foil edge to measure the profile at the same foil thickness

EDX detector positioned at the right side minimizes the X-ray path length through the specimen and the resulting absorption correction

In order to avoid scattering of the measured data close to the interface between the α and β lamellae, it is better to analyse only such cell regions where the β phase lamellae are removed by selective etching

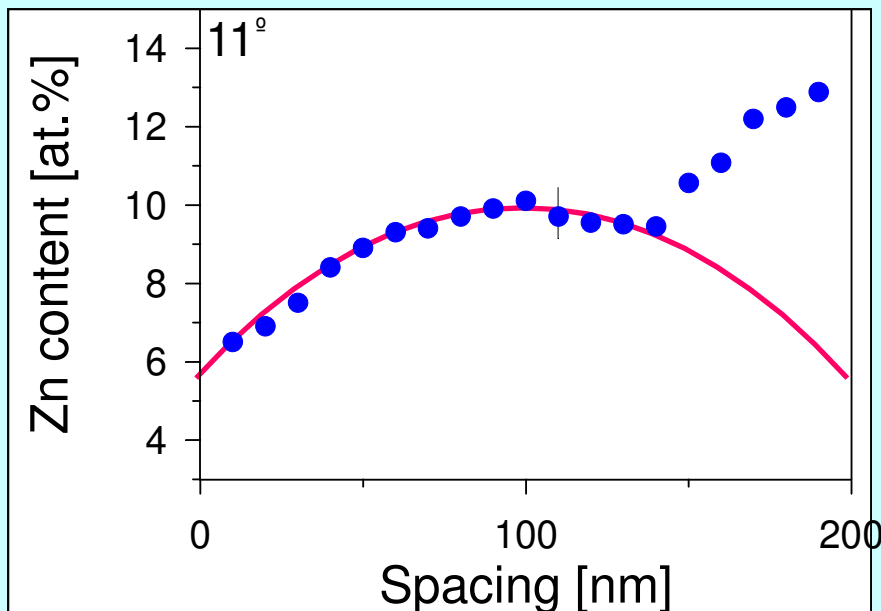
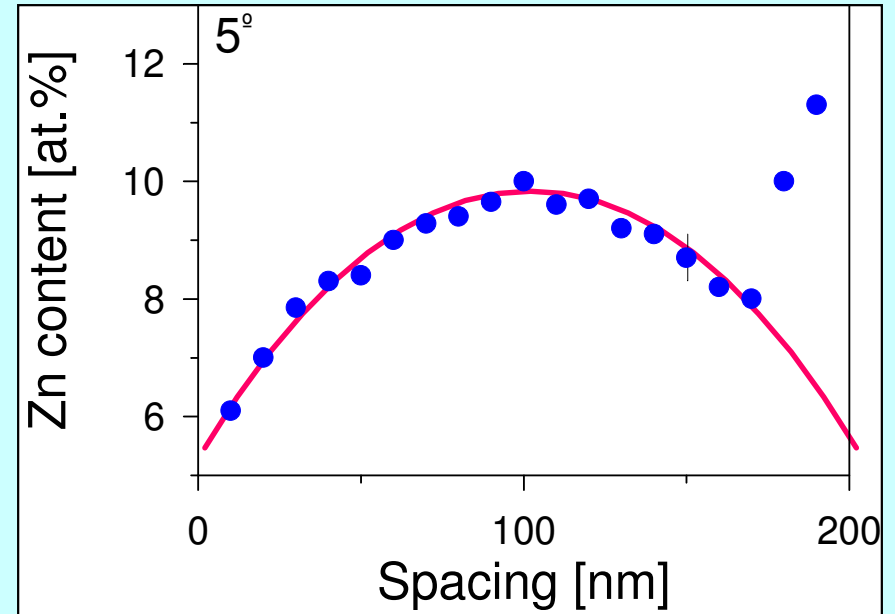
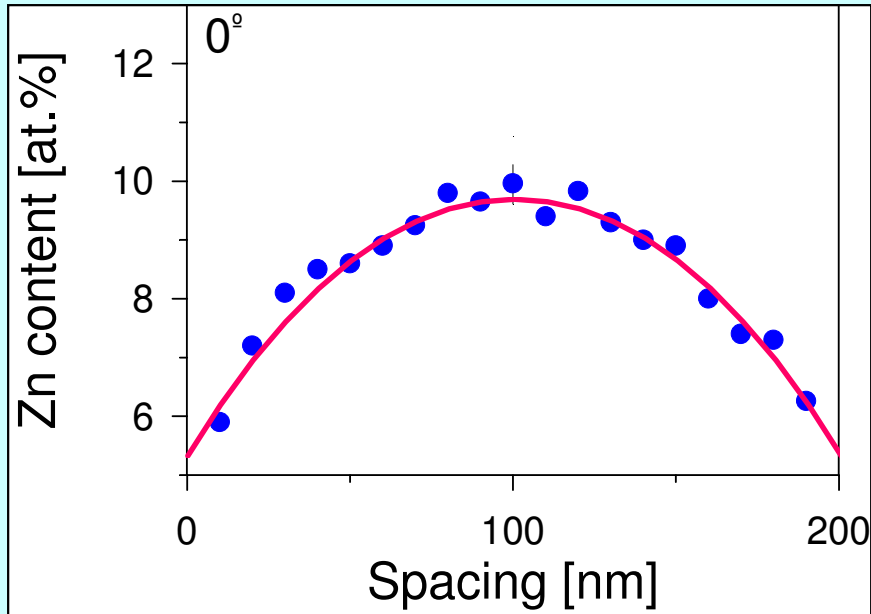

Solute distribution
across α lamella

P. Zięba, W. Gust:
Arch. Metall. 43 (1998) 217



Signal deconvolution

Analysed volume > Segregation volume at GB

The measured characteristic X-ray intensity for a particular element $I(V)$ is a convolution of the distributions of electron intensity $F(V)$ and the true element concentration $C(V)$ within the total sampled region of the foils

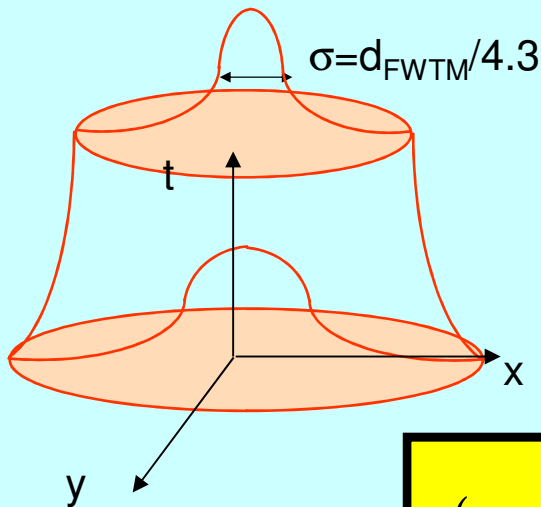

$$I(V) = K \int_V [F(V) \cdot C(V)] dV$$

$F(V)$: Gauss distribution

$$F(x, y, t) = \frac{i_b}{\pi(2\sigma^2 + \beta t^3)} \exp\left(\frac{-(x^2 + y^2)}{2\sigma^2 + \beta t^3}\right) \quad \beta = 500 \left(\frac{4Z}{E_o}\right)^2 \left(\frac{\rho}{A}\right)$$

$I(V)$ depends on the type of segregation at GB.

The convolution of $C(V)$ and $F(V)$ has to be done (iterations) up to full reproduction of experimental profile

Detectability limit

Minimum mass fraction (MMF) that can be measured in the analysed volume-smallest concentration of an element (wt.% or ppm)

Minimum detectable mass (MDM)-smallest amount of material (in mg or atoms) that can be detected

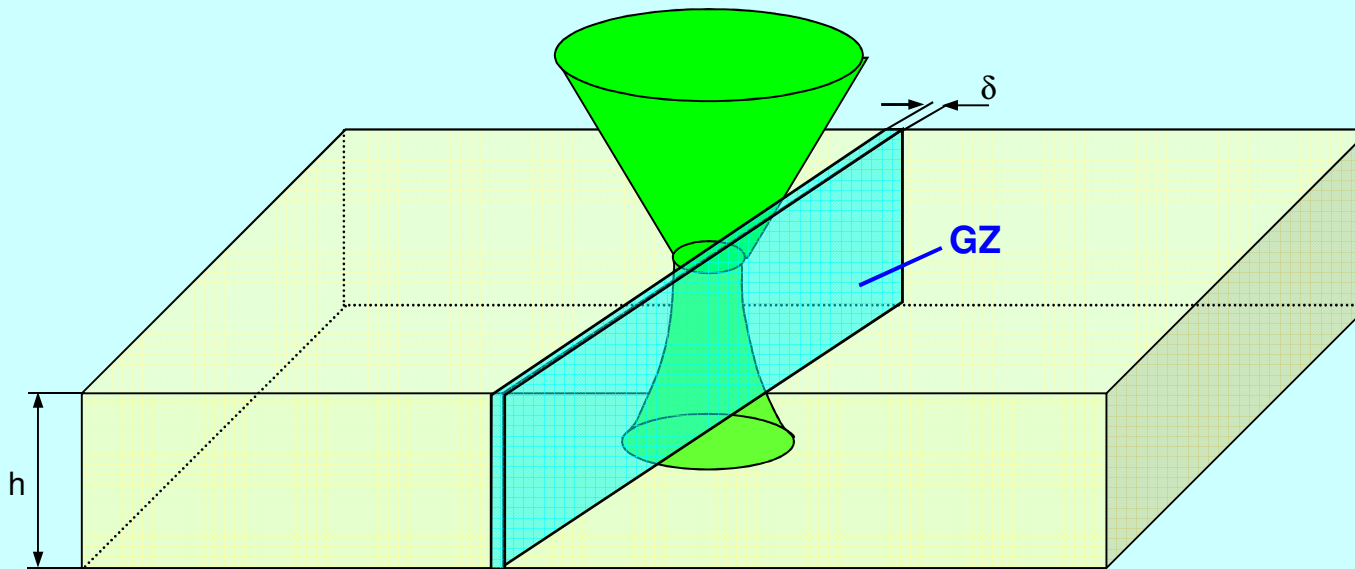

Parameters influencing detectability limit

- size of interaction volume
- intensity of incident beam
- beam broadening
- current density

Segregation detectability limit [atom/nm²]

$$\Gamma_{\min} \propto \frac{V}{A} \frac{1}{\sqrt{i_b}} \frac{1}{\sqrt{h}} \quad \frac{V}{A} = \sqrt{\pi} h \left(\int_0^h \frac{1}{\sqrt{2\sigma^2 + \beta t^3}} dt \right)^{-1}$$

ρ -the density of the matrix in atoms/nm³, i_b -the intensity in the X-ray peaks for the segregant
 V -the volume of the segregant, A -the area of the grain boundary within the interaction volume



Beam broadening \Rightarrow Gaussian model

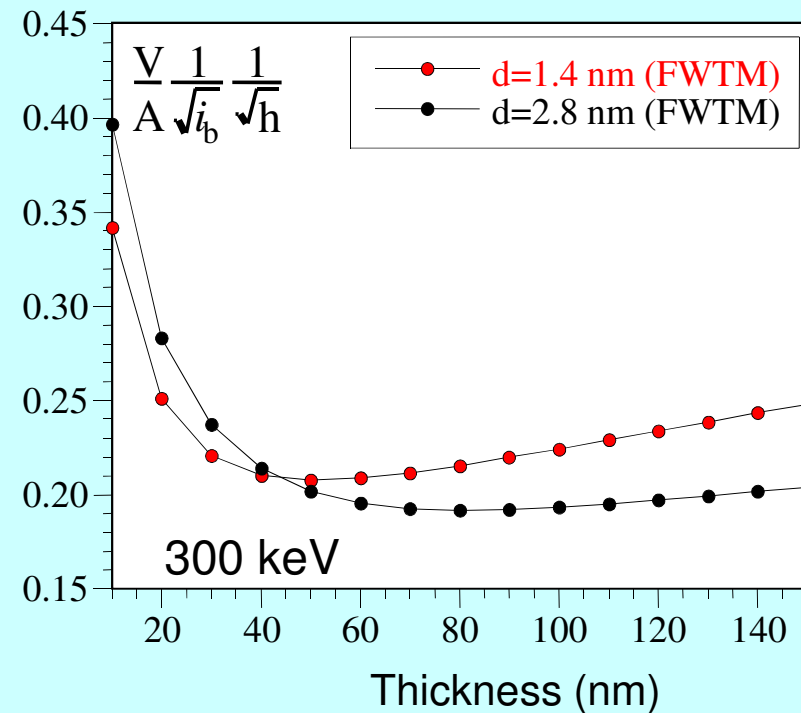
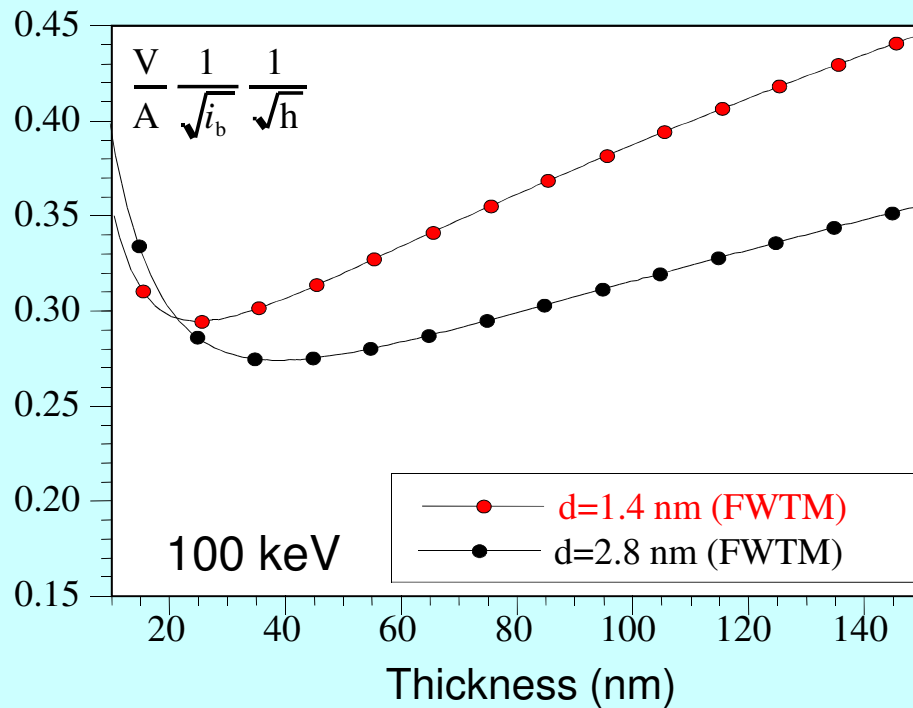

- Maximum detectability does not occur in the thinnest specimens or with the smallest probe sizes.
- Operating at 300 keV can improve detectability by a factor of 2.
- The effect of increasing thickness at 300 keV is relatively small.



Interfacial segregation

Equilibrium segregation

very thin layer - not more than several atom layers thick.
high level of alloying element enrichment – up to 100%.

Nonequilibrium segregation

large distance – from several nm to several mm.
small change of alloying element – \approx several wt.%

Influence on the macroscopic properties of the materials

loss of corrosion resistance.
increase of susceptibility to cracking.
loss of electrical properties (semiconductors).



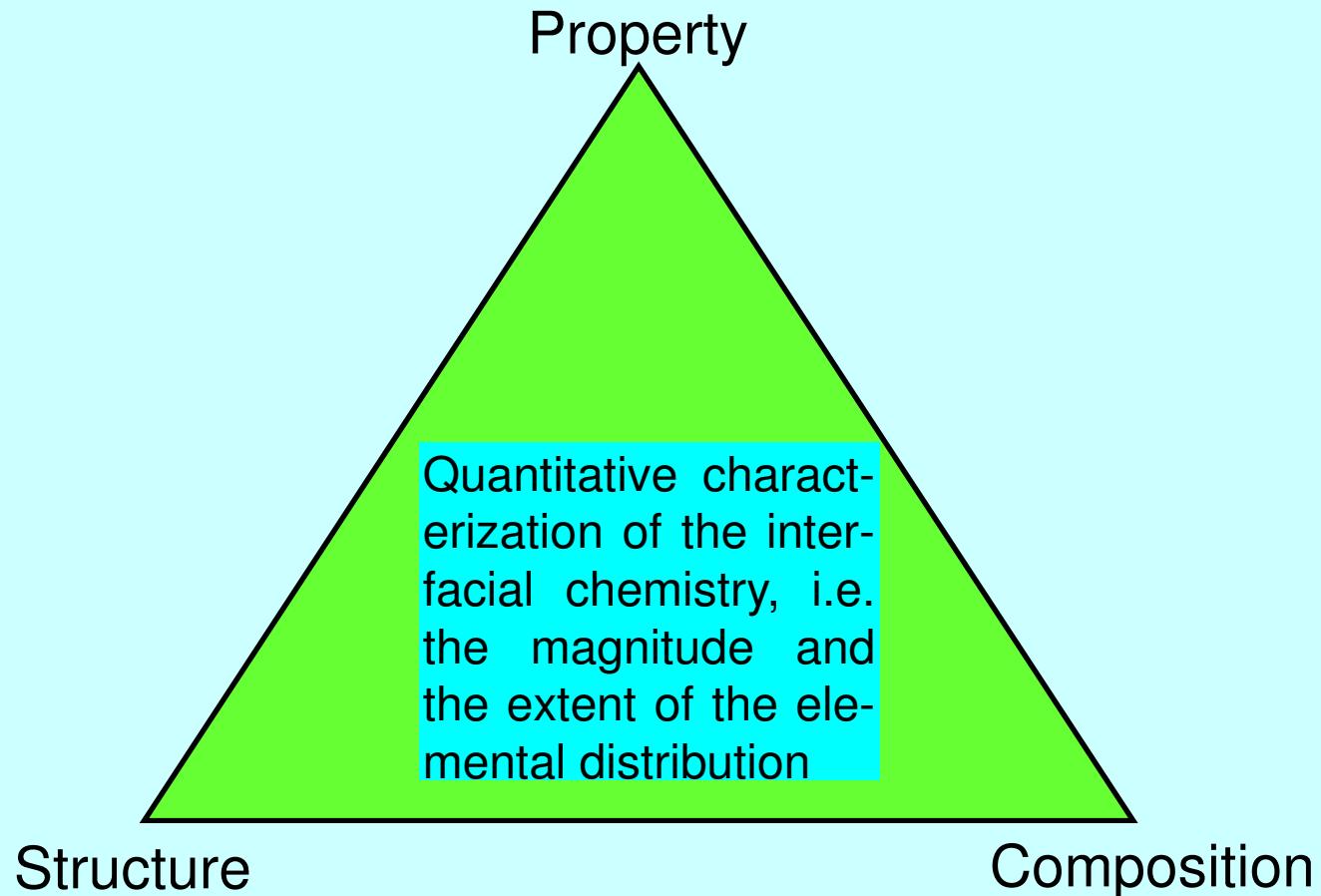

Heat-Affected Zone Cracking of Austenitic Fe-Ni-Cr Steel

Good combination of strength and corrosion resistance up to 925 K
Welding increases cracking susceptibility in HAZ
Reason: melting of Ti(C,N)

Material: austenitic stainless steel
Composition:
47Fe-32Ni-20.5Cr-0.35Cu-0.39Al-0.4Ti-0.045C-0.009S (wt.%)
Investigation details:
Probe size: 5 nm at FWHM
Foil thickness: »150 nm

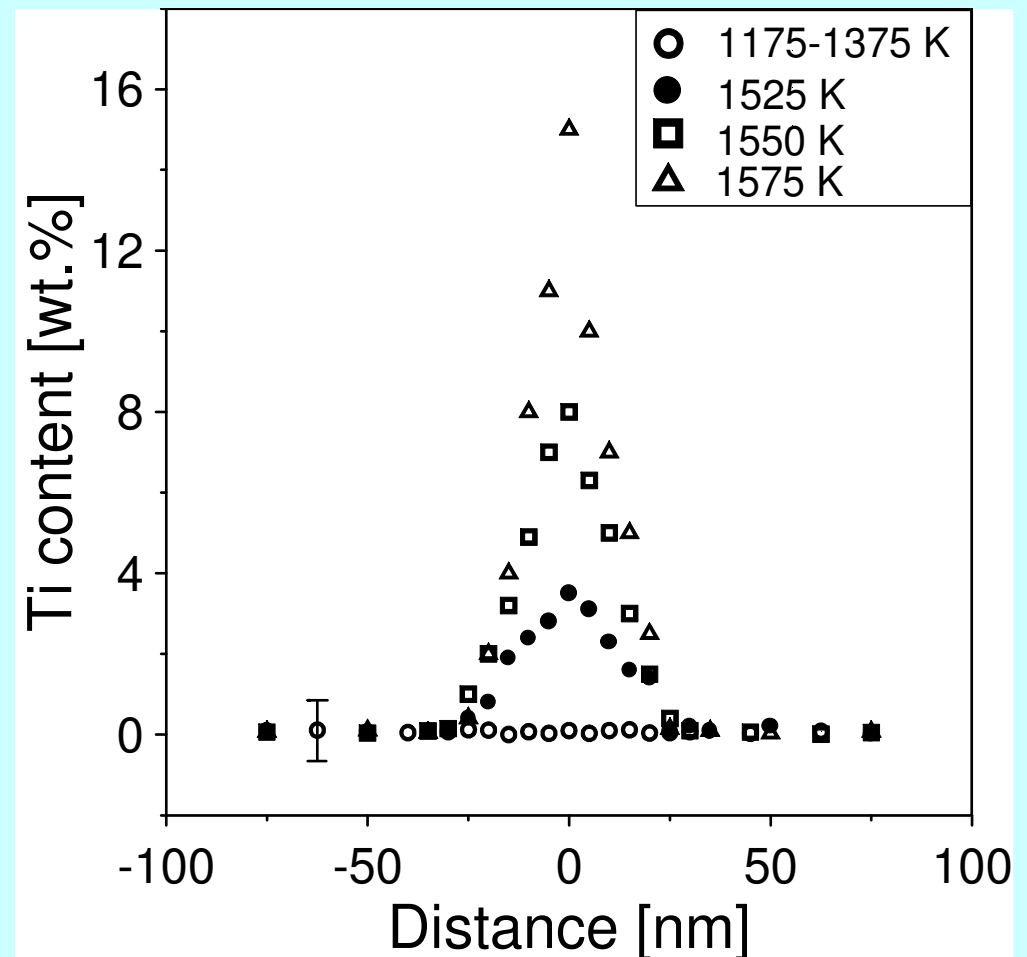

Deconvolution procedure - Truncated cone model

The depth distribution of the X-ray production is constant and the lateral distribution is given by a Gaussian one.

$$\frac{V_{GB}}{V_{tot}} = \frac{C_{exp} - C_m}{C_{GB} - C_m}$$

$$\frac{V_{GB}}{V_{tot}} = \frac{4\delta \ln [1 + (\ln 2 / \ln 10)^{0.5} \cdot b/d]}{\pi (\ln 2 / \ln 10)^{0.5} \cdot b}$$

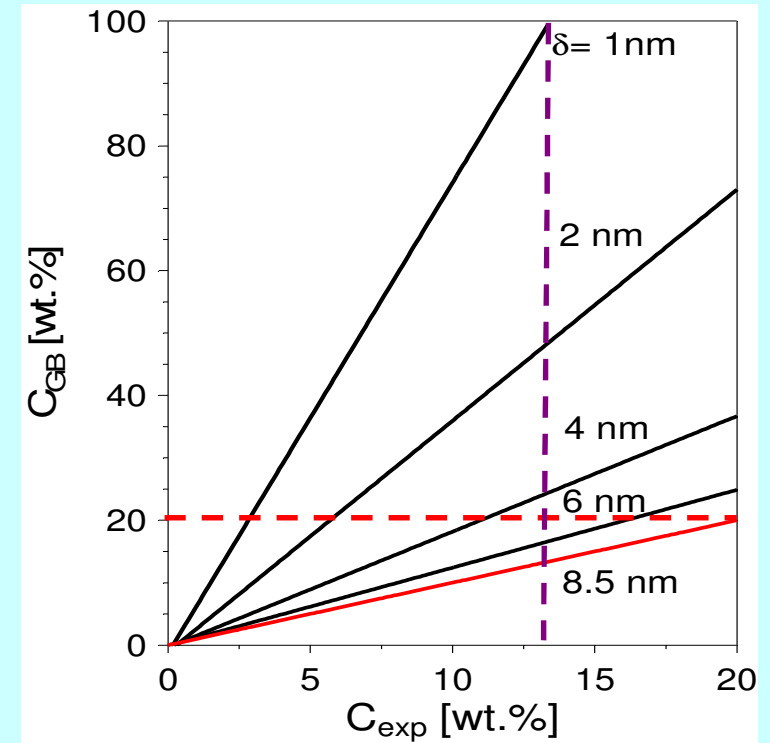
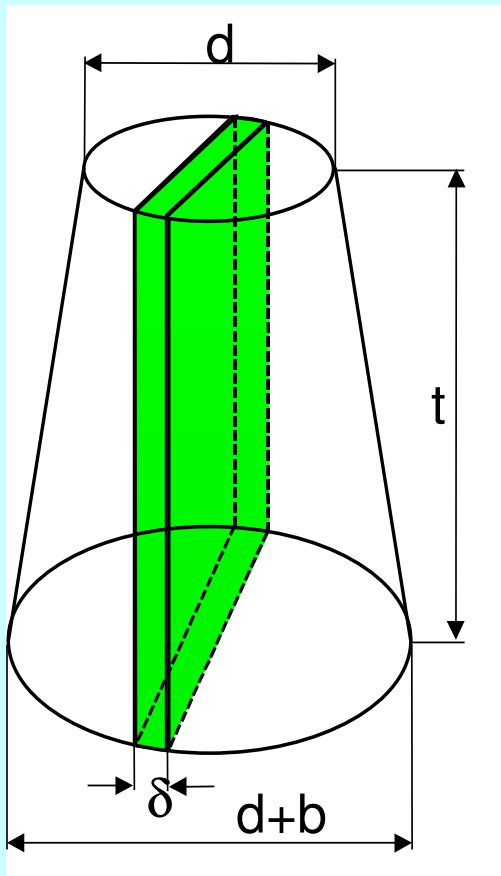

Sensitized stainless steel-loss of the corrosion resistance

Sensitization responsible for the breakdown of the corrosion resistance (825-1075 K)
Reason: precipitation of Cr-rich carbides at GBs

- Material: stainless steel
- Composition:
15Cr-10Ni-2.5Mo-1.7Mn-0.4Si
-0.03P-0.025C-0.085N (wt.%)
- Investigation details:
Probe size: 5 nm at FWHM
Foil thickness: 90-120 nm

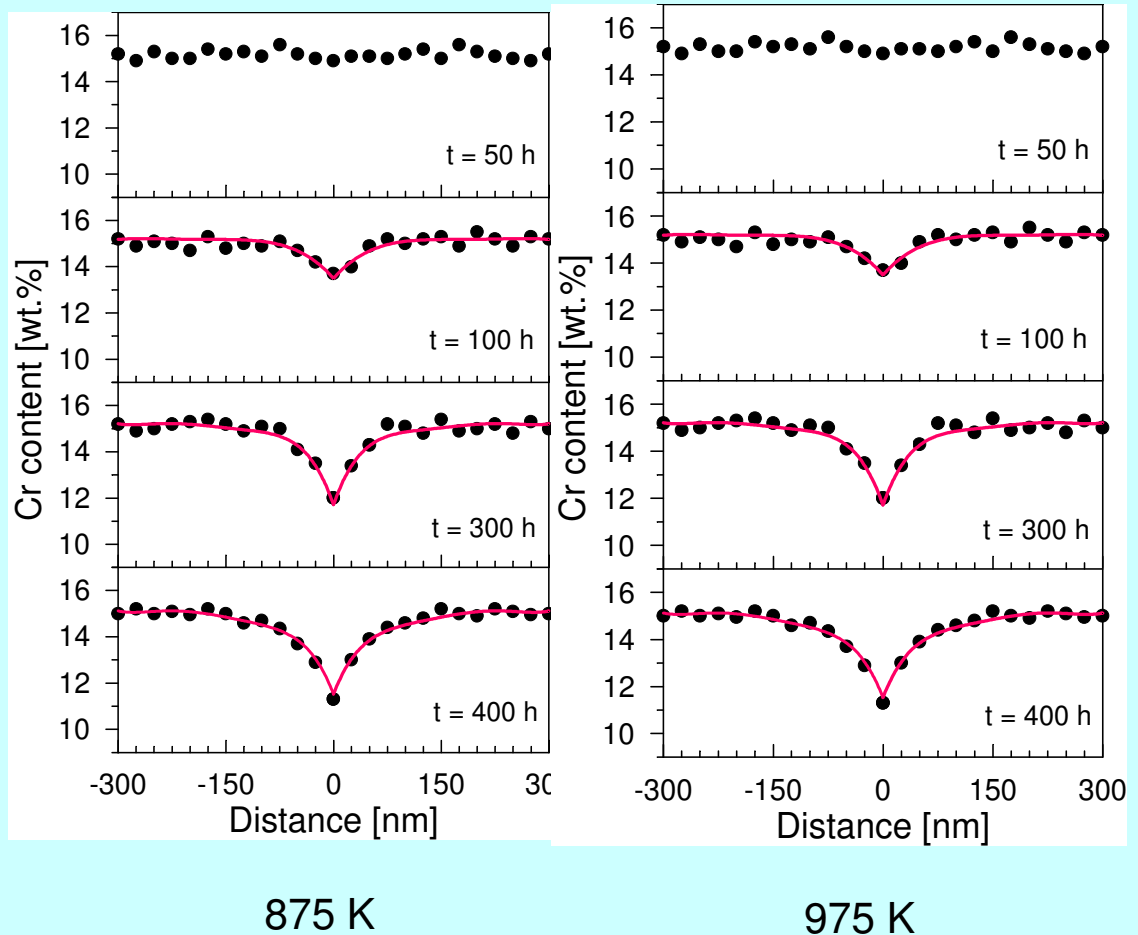

Metallization interconnect lines in the integrated circuits.

Electromigration-result of momentum transfer from electrons which are moving within the conductor to the ions which constitute the lattice of interconnect material. The electron flux results in a drift of the metal ions in the conductor leading to creation of voids and consequently damage of the conductor

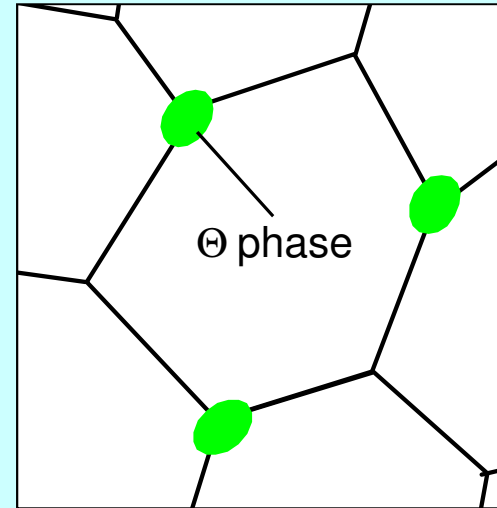
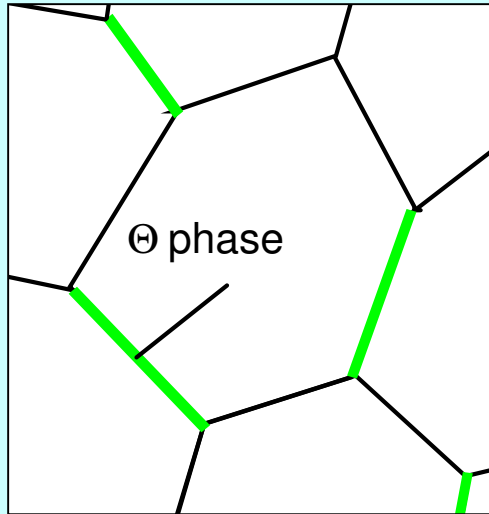

Investigation details: Material: Al-2 wt.% Cu alloy

Instrument	TEM-Philips CM 20	STEM-HB 601
Electron source	LaB ₆	Field emission gun
Accelerating voltage	200 kV	100 kV
Probe size	5 nm (FWHM)	1 nm (FWHM)
Foil thickness	200 nm	50 nm
Result	No segregation detected	See below



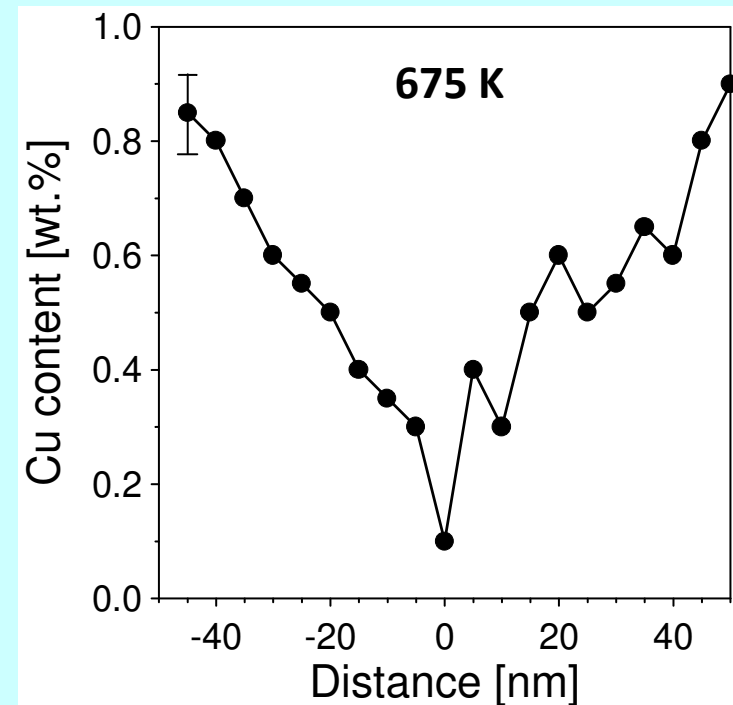
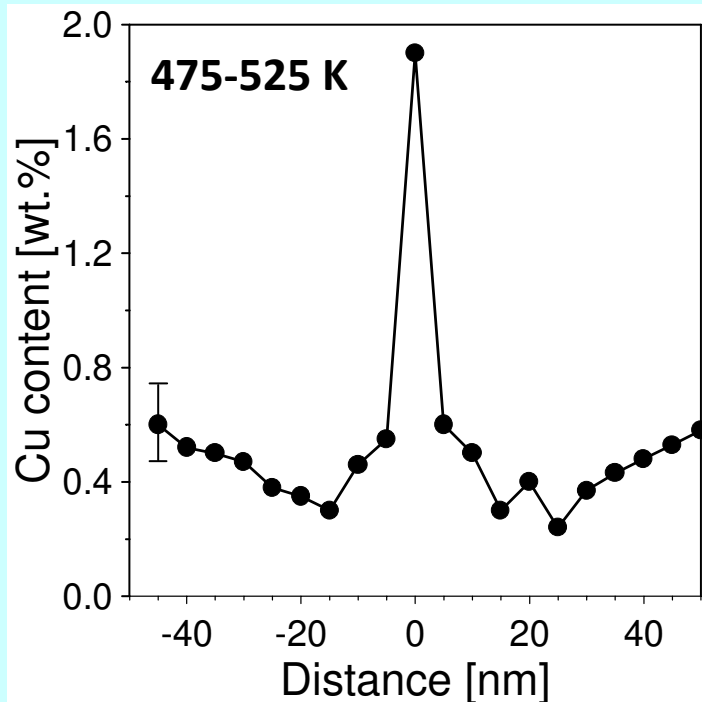

High temperatures: GB depletion by collector plate mechanism

Low temperatures: GB enrichment prevents GB migration

