

S. SCHMIDT* , D.J. JENSEN*

METAL STRUCTURES IN FOUR DIMENSIONS¹⁾

STRUKTURA METALU W CZTERECH WYMIARACH

The Three Dimensional X-ray Diffraction (3DXRD) microscope located at the European Synchrotron Radiation Facility (ESRF) in Grenoble, developed in collaboration between Risoe and the ESRF, utilizes high energy x-rays to investigate processes such as plastic deformation, phase transformation, recovery and recrystallization non-destructively in the bulk of materials.

Lately, an annealing experiment using a deformed aluminum single crystal has shown that it is possible to follow *in-situ* the evolution of the three dimensional shape of a single grain as function of annealing time, i.e. a four dimensional measurement of a recrystallizing grain. Contradictory to classical models, where the growth is assumed to be spherical and smooth, the measured grain exhibits a very irregular shape along with abrupt movements of the individual boundary segments. The experimental method also makes it possible to monitor the texture components of the deformed microstructure as it shrink in size due to growth of the recrystallized volume. The talk will give an overview of the experimental method and discuss its potential. In addition, a number of examples from the analysis will be presented. *par Keywords:* recrystallization, Boundary migration, 3D, 3DXRD

Trójwymiarowa mikroskopia dyfrakcji rentgenowskiej (3DXRD) zlokalizowana w European Synchrotron Radiation Facility (ESRF) w Grenoble, rozwinięta we współpracy pomiędzy Risoe i ESRF wykorzystuje wysokoenergetyczną wiązkę rentgenowską do nieniszczących badań takich procesów jak deformacja plastyczna, przemiana fazowa, zdrowienie i rekrytalizacja w objętości materiału.

Ostatnio, możliwa jest obserwacja *in-situ* rozwoju rekrytalizacji 3-wymiarowego kształtu pojedynczego ziarna odkształconego monokryształu aluminium w funkcji czasu wygrzewania, tj. czwartego wymiaru. W odróżnieniu do modeli klasycznych, w których zakłada się regularny i sferyczny wzrost, mierzone ziarno wykazuje bardzo nieregularny kształt z gwałtownymi przemieszczeniami segmentów granicy pojedynczych ziaren. Wprowadzona metoda eksperymentalna umożliwi również monitorowanie składowych tekstury odkształ-

* CENTER FOR FUNDAMENTAL RESEARCH METAL STRUCTURES IN FOUR DIMENSIONS, RISOE NATIONAL LABORATORY, FREDERIKSBORGVÆY 399, DK-4000, ROSKILDE, DENMARK

¹⁾ invited lecture

conej mikrostruktury kurczącej się podczas wzrostu objętości zrekrytalizowanej. W pracy omówiono metodę i przedyskutowano jej możliwości, podając wiele przykładów zastosowania.

1. Introduction

We present an experimental method where details on local grain boundary motion of a recrystallizing bulk grain within a deformed matrix can be measured *in-situ* and non-destructively [1] utilizing the 3DXRD microscope [2]. The method allows detailed 3D studies on the development of grain boundary morphology during annealing processes. In addition, we report on new results obtained by extending the experimental method to include measurements of the deformed microstructure.

2. The 3DXRD microscope

The Three Dimensional X-ray Diffraction microscope (3DXRD) [2], developed in a collaboration between Risoe and the European Synchrotron Radiation Facility (ESRF), is a new technique for fast and non-destructive characterization of the local microstructure in the bulk of materials. The microscope is situated at beamline ID-11 at the ESRF in Grenoble, France.

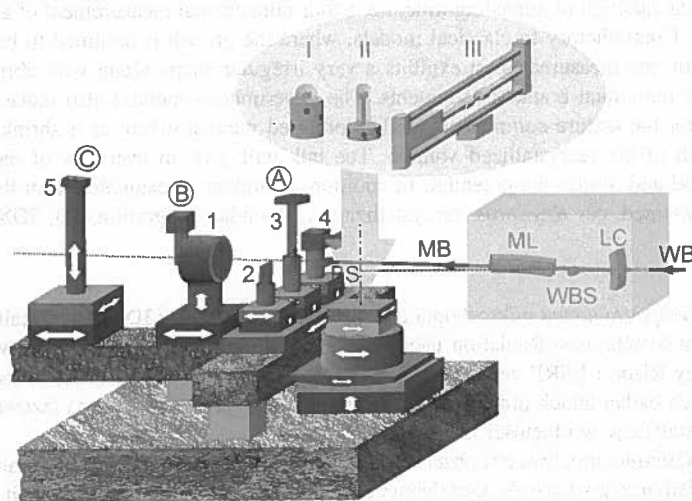

Fig. 1. Schematic view of the current 3DXRD microscope. WB: White beam, LC: Bent Laue crystal, ML: Bent multi layer, WBS: White beam stop, MB: 2 dimensionally micro focussed monochromatic beam, BS: monochromatic beam stop. Sample environment I: Cryostat, II: Furnace, III: 24kN Stress rig. Detectors: 1: Large area detector, 2: Conical slit system, 3: High resolution area detector, 4: Optional detector system, 5: Small area detector

A schematic view of the microscope is shown in Fig. 1. The white beam (WB) from the synchrotron ring is mono-chromized and focused vertically using a bend Laue silicon single crystal (LC) yielding energies in the range 50-100 keV, enough to penetrate 4 cm aluminium or 1 mm of steel, with a cross section between 1-200 μm vertically, and 1000 μm horizontally [3]. An optional multi layer (ML) [4] focuses the monochromatic beam (MB) horizontally down to 5 μm with enough flux to resolve microstructures below 1 μm [5].

For annealing studies a furnace (II) is mounted on the rotation stage located downstream from the focusing optics. The direction of the rotation axis is perpendicular to a vertically focused beam and the amount of rotation is given by ω , see Fig 3. In order to cover the whole reciprocal space, a set of images are recorded by successively moving $\Delta\omega$ and oscillation $+\Delta\omega/2$ around that point. Diffraction images are collected using two-dimensional CCD detectors. High-resolution detectors (A), with pixel size of roughly 2 μm , are positioned closely to the sample giving information about the grain shapes, whereas low-resolution detectors (B), with pixel size of roughly 100 μm and much faster readout electronics, are used at larger distances for integrated grain volume and angular information, the latter for determining the crystallographic orientations of the grains.

3. Recrystallization in four dimensions

An aluminum single crystals of initial crystallographic orientation $\{110\}\langle 001 \rangle$, i.e. Goss, was deformed 42% by cold rolling to ensure enough driving force for recrystallization boundary migration keeping the resulting deformed microstructure relatively simple, see Fig. 2A. As seen in Fig. 2B, the mean orientation is still close to ideal Goss, with a spread of roughly 8 degrees. Controlled nucleation was stimulated by diamond shaped hardness indentations on the surface of the sample. The size of the sample was 1 mm along ND, 6 mm along RD and 5mm along TD.

Full 3D spatial information of a growing nucleus/grain was obtained nonby utilizing the 3DXRD microscope. A schematic view of the experimental setup is shown in Fig. 3. A planar shaped beam with a height (Full Width Half Maximum) of a 6 μm and a width of 600 μm was applied. The sample was mounted such that initially, ND was along the incident beam direction, TD transverse to it and RD was normal to the beam direction. For a given nucleus/grain fulfilling the Bragg criterion the illuminated region constitutes a cross section of the grain and results in a diffraction spot on the detector of a shape given by the real cross section of the nucleus/grain except for an affine transformation related to the direction of the diffracted beam. By repeatedly recording an oscillation image with $\Delta\omega = 0.5^\circ$ followed by a 6 μm vertical translation of the sample, a "snapshot" of the grain was recorded, see the insert in Fig. 3. In this way 3D grain shapes were obtained non-destructively. The annealing temperatures were in the range 280°C to 310°C. The recording time per "snapshot" was typically 10 minutes. By repeating this procedure over time, while

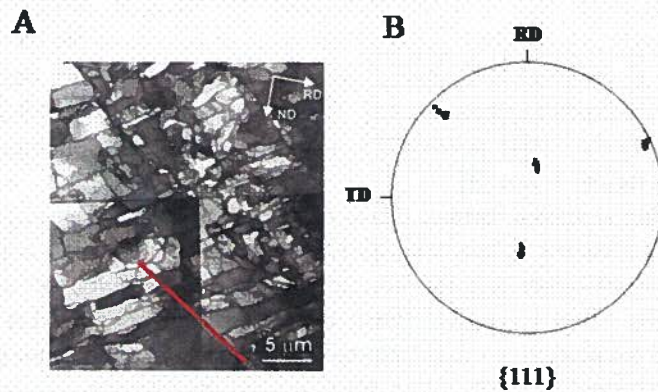

Fig. 2. A) Montage of TEM micrographs of 42% cold rolled Al single crystal with initial orientation $[110]\langle 001 \rangle [1]$. B) $\{111\}$ Pole figure of crystallographic orientations measured along a straight line shown in Figure 2A. An orientation spread of roughly 8 degrees around the initial Goss orientations is seen

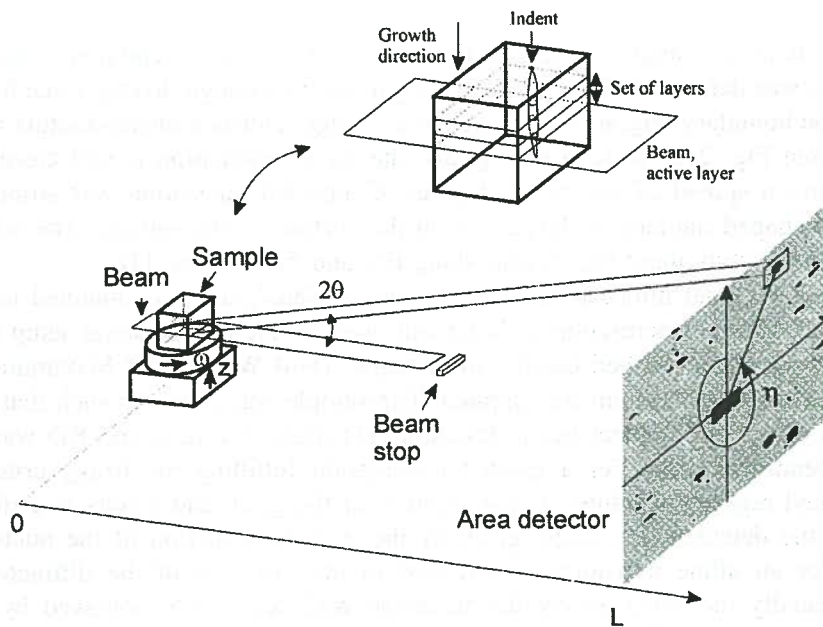

Fig. 3. Schematic view of the experimental setup. The coordinate system (x,y,z) and angles $(\omega, 2\theta, \eta)$ are defined. L denotes the distance between the sample and the CCD detector

annealing the sample, 4D (space and time) grain maps were obtained nondestructively [1]. An example is shown in Fig. 4. It is seen that the grain started out as a small flattened object, as opposed to later stages where the shape, resulting from a series of abrupt growth intervals, appeared much more complicated, clearly in contrast to the assumption of smooth steady-state growth in the classical models of recrystallization.

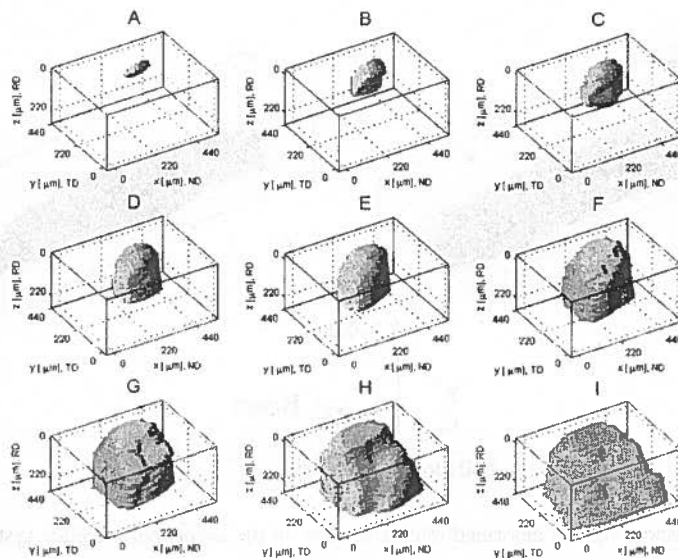

Fig. 4. Storyboard of the evolution of a grain represented by 9 "snapshots" [1]

4. Deformed microstructure

The deformed microstructure in the sample can also to some extent be monitored through the experimental method described previously. From TEM measurements, see Fig. 2, the typical cell size in the deformed microstructure has been measured to 2-5 μm . Signals on the CCD detector arising from the deformed microstructure comprise of cells present in the illuminate region, given by 1000 μm (along x direction) by 700 μm (along y direction) by 6 μm (along z direction), which fulfill the Bragg criterion. With $\Delta\omega = 0.5^\circ$ and an orientation spread in the deformed microstructure of roughly 8° , not all cells deposit intensity in one oscillation image. Despite of this it is not possible to disentangle the diffraction signal from the individual cells due to geometrical limitations in the experimental setup, i.e. the low inclination of the diffracted beam and the pixel size on the CCD detector. Instead, a superposition of cells distributed throughout the illuminated region is recorded. Fig. 5A shows a "snapshot" of the deformed structure at an early annealing stage. The shape in Fig. 5A resembles a box which

effectively is the total gauge volume consisting of 30 layers. Fig. 5B shows the same gauge volume after 25 hours of annealing. The volume of the deformed microstructure has been reduced at the expense of the increasing recrystallized volume. In fact, the reduced volume is a “photographic negative” of the recrystallized volume where the shapes of all the recrystallizing grains in the gauge volume are present.

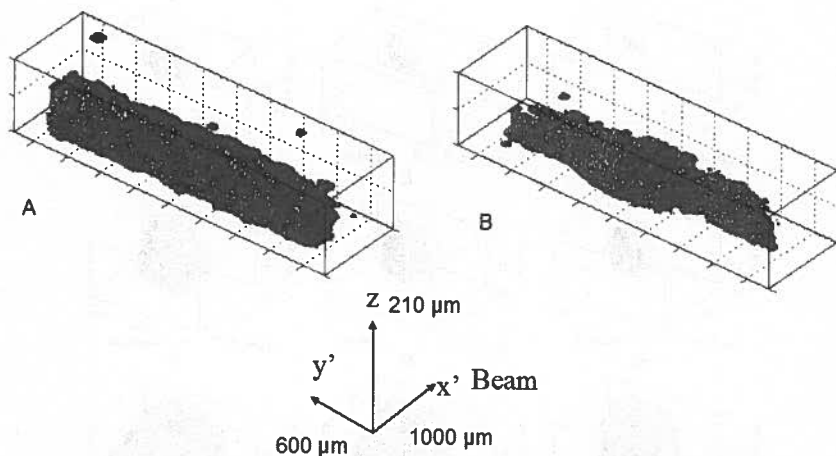

Fig. 5. Two “snapshots” of the deformed microstructure. In the ω -rotated reference system x' is along, y' is transverse and z is normal to the beam direction, respectively. As noted in the figure, the size of the gauge volume is $1000 \mu\text{m}$ along x' , $600 \mu\text{m}$ along y' and $210 \mu\text{m}$ along z . A) before annealing B) After 20 hours of annealing. These “snapshots” constitute a “photographic negative” of the recrystallized volume

5. Summary

The 3DXRD microscope facilitates observations of structural changes in the bulk of materials non-destructively. Recently, the evolution of the individual shapes of recrystallizing grains have been observed as a function of annealing time in the bulk of deformed Al single crystals [1]. All the grains measured so far exhibited irregular movements contradicting the assumption of smooth growth in the classical models of recrystallization. The information content provided in this new type of measurements makes it possible to probe the mechanisms of recrystallization *locally* since the position of individual grain boundary segments are known along with the crystallographic orientation of the recrystallizing grain as well as the average orientation of the surrounding deformed microstructure.

REFERENCES

- [1] S. Schmidt, S.F. Nielsen, C. Gundlach, L. Margulies, X. Huang, D. Juul Jensen, *Science*, **305**, 229-232 (2004).
- [2] H.F. Poulsen, S. Garbe, T. Frello, R. Reidenhans 'l, H. Graafsma, *J. Synchrotron Rad.*, **4**, 147- 154 1997.
- [3] U. Lienert, C. Schulze, V. Honimäki, T. Tschentscher, S. Garbe, O. Hignette, A. Horsewell, M. Lingham, H.F. Poulsen, N.B. Thomsen, E. Ziegler, *J. Synchrotron Rad.*, **5**, 226-231 1998.
- [4] U. Lienert, H.F. Poulsen, V. Honimäki, C. Schulze, O. Hignette, *J. Synchrotron Rad.*, **6**, 979-984 1999.
- [5] H.F. Poulsen, E.M. Lauridsen, S. Schmidt, L. Margulies, J.H. Driver, *Acta Metall. Mater.*, **51**, 2517- 2529 2003.

Received: 24 January 2005.