

ANALYSIS OF THE STATE OF STRESS IN CATHODE BLOCK OF AN ALUMINIUM ELECTROLYTIC CELL DURING FORMATION OF CONNECTION WITH THE STEEL PIN BY CAST IRON POURING

The article presents various aspects of the analysis of the state of stress in carbon block induced by the effect of temperature when a steel pin is connected to the block by pouring a shaped groove with cast iron. Changes in the temperature and state of stress in the block were examined by FEM (Abaqus program). The numerical model was validated by experimental measurements of pin deflection during pouring of the groove with cast iron.

Keywords: aluminium electrolytic cell, cathode section, cast iron, FEM calculations

1. Introduction

Proper design and execution of a single cathode section (Fig. 1) which, combined with other sections, makes lining of the bottom of an aluminium electrolytic cell is important for the service life of the plant and energy consumption during the process of electrolysis.

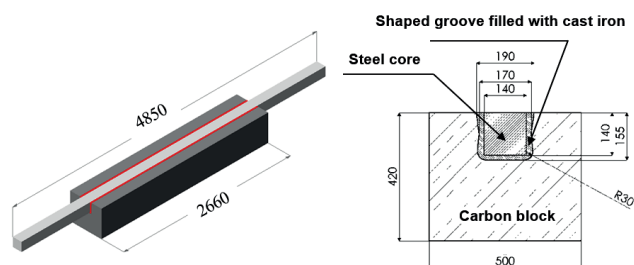

Fig. 1. Single cathode section in a ready-for-pouring position and its dimensions adopted in the numerical model

Industrial practice shows that cathode destruction is the leading cause of premature decommissioning of the plant for renovation. In the case of modern carbon materials, the failure-free operation of cathode is possible for a period of approximately 120 months. Only after this time, the cathode material is being destroyed due to the unavoidable effect of mechanical and chemical erosion. In practice, however, early decommissioning of cells from the operation after 48 or even 24 months is frequently observed [1] [2] [3]. If this happens, it means a catastrophic wear and tear of the cathode, caused by cracks initiating and propagating in the carbon material. At this point it should be mentioned that the conditions under which the cell lining operates and the conditions under which the cathode sections are produced are unstable and uncertain. The structure of the cathode section is often exposed to thermal and

mechanical overload exceeding the strength of the material from which it has been made. This is evidenced by damages and failures in the cathode section during operation and when the block is connected to a pin [4] [5]. Additionally, the carbon material is porous and its strength is not uniform in the whole volume of the block, often differing quite considerably from the values determined in trials. The quality of cathode section largely depends on the design and execution of connection between the steel pin and carbon block. The connection has certain specific characteristics, which include large difference in the properties of connected materials, thermal overload suffered by components when the connection is being made, lack of wettability of the carbon material by cast iron, and practical use of the difference in thermal expansion of materials to produce a strong bond. Additionally, a connection of this type should meet two conditions, namely transfer mechanical loads and have the lowest possible electrical resistance. Rational approach to the design and performance of connection requires analysis of the temperature field and state of stress in the cathode section when the connection between elements is made, and later during the start up and stable operation of the cell, to ensure that the whole structure is as far as possible insensitive to thermal and mechanical overload. The complexity of problems requires the use of numerical methods for calculation of the field values. The article presents selected issues related to the construction of a FEM model used for analysis of the state of stress in carbon blocks connected to a steel core by cast iron pouring, and for analysis of the results obtained.

2. The process of making single cathode section

The process of making single cathode section consists of two steps, which are executed in different industrial plants. Plants manufacturing products from carbon materials supply

* AGH UNIVERSITY OF SCIENCE AND TECHNOLOGY, FACULTY OF FOUNDRY ENGINEERING, DEPARTMENT OF FOUNDRY PROCESS ENGINEERING, AL. A. MICKIEWICZA 30, 30-059 KRAKÓW, POLAND

Corresponding author: mmaj@agh.edu.pl

to the aluminium smelting plant carbon blocks of a specific size and with specific physical and chemical properties. The second step, which involves making the connection, is usually carried out in a foundry forming part of the aluminium smelting plant. The technology by which the connection is made between the carbon material and the steel pin, using cast iron to fill the free space in a shaped groove of the cathode block, creates thermal stresses which in some cases may exceed the strength of the carbon material and result in the formation of cracks. The thermal shock is significantly reduced when the block and the pin are preheated before pouring of cast iron, the latter operation being done either directly from a ladle or using a spray gating system. The negative effect of thermal shock can be mitigated by sequential pouring of the carbon block, which means dividing the shaped groove into several “compartments” separated with walls made of a ceramic material or carbon paste. Cast iron is then poured separately into the individual “compartments” of the groove in a fixed sequence and at fixed intervals. The use of this specific technology increases the number of sound blocks, but leads to an unfavourable increase in the section resistivity.

3. The phenomena accompanying pouring of cast iron into the shaped groove

The temperature field created in the steel pin and carbon block by the heat flux formed during cooling of cast iron bends the block and the pin in opposite directions. The “ends up” bending of the pin makes the contact resistance increase in the end areas of the block, and through mechanical action can also increase the stress level in the block. The locally exceeded strength of the material induces the formation of cracks, which are usually located in two areas of the block. Transverse or angular cracks are formed in the middle of block length on its external upper edges and propagate in a plane perpendicular to the longitudinal axis. They are caused by excessive growth of local tensile stress extending along the upper edge of the block. The second place where cracks may form is the front surface of the block. Double V or wing cracks are typically running at an angle of about 45° from the lower surface of the shaped groove in the direction of side walls. The cracks may have different lengths, and some of them may close due to lower stress after cooling down of the block. However, the state of stress in the cathode when the cell starts operating promotes the development of cracks already existing. The lack of wettability between carbon and cast iron means the lack of any chemical or electrical bonding between them, and therefore the connection is of purely mechanical nature. The shrinkage that occurs during solidification and cooling between the cast iron and the side surfaces of a carbon block creates a gap which, within some dimensional limits, allows for the free movement of pin. On the magnitude of this movement will depend, on the one hand, the magnitude of stress, and on the other, the electrical resistance of the connection. The groove, whose properly shaped sidewalls form with the cast iron a “dovetail” type mechanical lock, prevents drawing out of the pin during transport operations. Cracks formed in the stage of making the connection can be

prevented by proper control and selection of the following quantities and parameters:

- fillet radius of the shaped groove,
- heating temperature,
- distribution of cathode blocks during heating and pouring,
- pouring temperature and chemical composition of cast iron,
- volume of cast iron poured into the shaped groove,
- time lapse between the end of heating and pouring.

4. The numerical model of cathode section

Numerical calculations by FEM were performed with an Abaqus software. For spatial discretization of a model of cathode section (Fig. 1), 8-node linear elements were used. The developed model served as a tool for the analysis of temperature field, and the displacement and state of stress during pouring and cooling of cast iron in the shaped groove. The calculations allowed for an impact of temperature changes on the value of specific heat, thermal conductivity, density, coefficient of linear expansion and modulus of elasticity of the carbon material, cast iron and steel. The anisotropy of carbon material was also considered and illustrated by variations in the aforementioned thermal and mechanical properties along the major axis of the block and in the direction perpendicular thereto, resulting from the technology by which carbon blocks are shaped [6] [7] [8] [9] [10]. As regards heat exchange between the cathode section and the environment, a boundary condition of the third kind was adopted assuming the continuity of heat flux flowing to the edge of the examined area and carried away to the environment. Due to the fact that the examined areas were heterogeneous, this condition was completed with the condition of the fourth kind on the contact surfaces between the carbon block and cast iron, and between the cast iron and pin. For the boundary conditions of heat exchange, the following values were considered constant: thermal resistance of the gap, heat transfer coefficient, and ambient temperature. All these quantities were selected from the Magma database. The examined model of transient heat flow required the determination of an initial condition describing temperature field. The initial temperature was assumed to have equal values in the whole system of the carbon block and steel core, while temperature of the cast iron, which at the time $t = 0$ filled the entire shaped groove, was constant. The previously mentioned effect of pin movement in the shaped groove induced by thermal shock required an adjustment made in the numerical model to allow for the mechanical contact that might occur in the case of an interaction between the surfaces of two elements. It has been assumed that one of them is the shaped groove surface and the other is the surface of the solidified cast iron rigidly connected to a steel core. The pin is free to deform until it experiences a resistance from the surface of the groove. Then the forces normal and tangential to the interacting surfaces appear. In the stress model of a cathode section it has been assumed that the section is freely resting on a non-deformable plane and is exposed to the effect of forces originating from the mass of the system.

5. Temperature field and state of stress in carbon block during cooling of cast iron in the shaped groove

Pouring of the shaped groove with cast iron brings rapid rise of temperature on the groove surface. The isotherms move inside the block in directions perpendicular to its three surfaces. Depending on the thickness of cast iron layer, usually ranging from 15 mm to 25 mm, the highest temperature of 720°C to 920°C is reached on the groove surface after approximately 30 seconds since the time instant of filling the groove with cast iron. If the block has been pre-heated, in parallel with heating of the block material on the side of the groove, there is a drop of temperature on the outer surfaces.

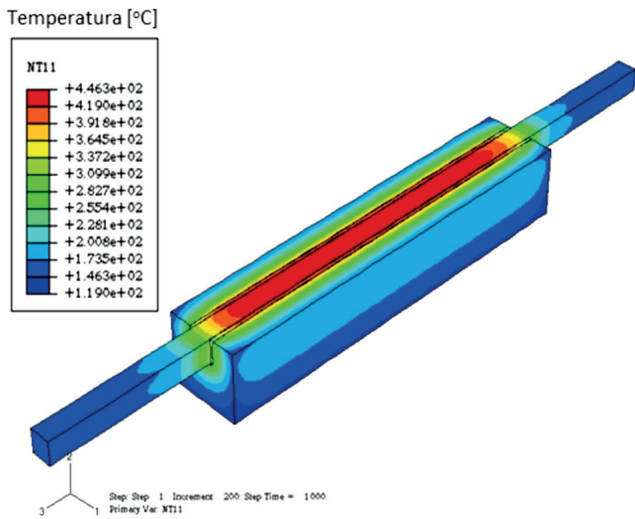

Fig. 2 Temperature field in cathode section after the lapse of 1000 seconds since the time instant of filling the groove with cast iron; the initial temperature of the heated section is T=200°C

The greatest difference in the temperature of the groove surface and outer surface of the block occurs during the initial 180 seconds (Fig. 2).

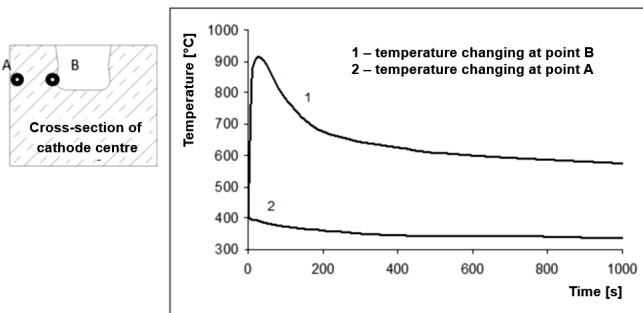

Fig. 3. Temperature changes in the cross-section of cathode centre; the initial temperature of the heated section is T = 200°C

After this time, the gradient stabilizes and a uniform drop of temperature takes place in the whole block. As shown by calculations, rapid temperature increase occurs only in a limited area around the groove cross-section. At a distance of 45 mm from the surface, the temperature rises by not more than 100°C, and at a distance from the surface larger than 85 mm, the rise of temperature does not exceed 40°C. In the time

interval of the greatest difference between the temperature of the groove surface and outer surface of the block, the zone of overheating does not exceed 25 mm. The reason for the slow propagation of heat is the low thermal conductivity of carbon material. It causes heat accumulation in a relatively small area and the formation of large temperature gradients. The variable temperature field induces in the carbon block the formation of a specific field of thermal stresses. To make analysis of the state of stress in the block it is convenient to assume a division of the block into three separate parts (Fig. 4).

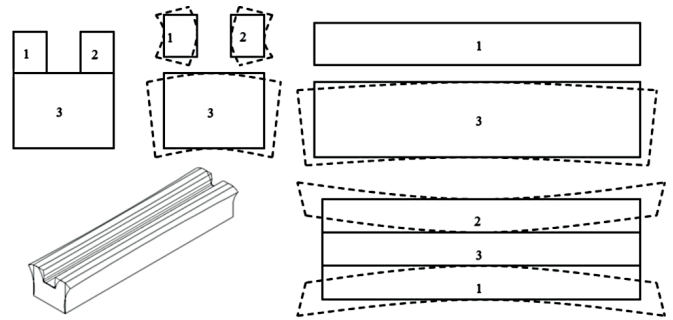

Fig. 4. Bending of block components under the effect of heat

Thus divided block can be regarded as a system of three separate unilaterally heated beams, the bending of which occurs in the direction pointing towards the heat source. In this case, the temperature distribution described by function $T = T(y)$ depends on one coordinate only, perpendicular to the axis of the beam. At a distance sufficiently large from the free ends of the beam, the distribution of stress σ_x parallel to the major axis of the beam can be described by the following equation [11]:

$$\sigma_x = -E\alpha T(y) + \frac{1}{h} \int_{\frac{h}{2}}^{\frac{h}{2}} E\alpha T(y) dy + \frac{12y}{h^3} \int_{\frac{h}{2}}^{\frac{h}{2}} E\alpha T(y) y dy \quad (1)$$

where:

- E – the modulus of elasticity,
- α - the coefficient of linear expansion,
- a, b - the width and height of the beam, respectively.

In thus divided beams, the state of stress induced by unilateral heating adopts the form of one of the three cases shown below, depending on the mode of beam constraint (Fig. 5).

The non-linear distribution of temperature in a unilaterally heated free-ends beam (Fig. 5a) induces the state of stress characterized by a double change of sign (Fig. 5b). The layers of the beam adjacent to the heat source are compressed, in the central part the effect of tension occurs, while layers on the side opposite to the heat source are again compressed. This stress distribution has been confirmed by both experimental studies and numerical calculations [12] [13]. During thermal shock, the width of the stretched zone and of both compressed zones changes, the beam undergoes deformation but compressive stresses in its outer layer prevent the formation of cracks. A different and much less preferred state of stress occurs in the beam which at both ends is exposed to the effect of bending moment counteracting the thermal deflection

(Fig. 5c). In this case, on the side opposite to the heat source, the tensile stress will rise promoting the crack initiation and propagation. The magnitude of this stress can be reduced by compression exerted on the beam along its major axis (Fig. 5d). Based on the conducted numerical calculations, the state of stress was determined in different parts of the carbon block (Fig. 6).

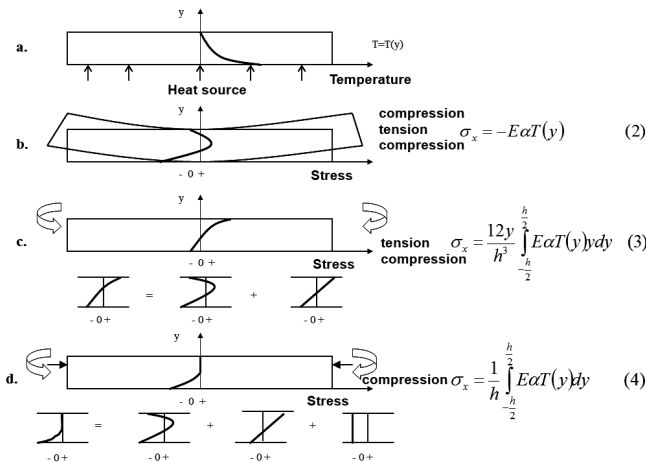

Fig. 5. Different states of stress σ_x in unilaterally heated beams dependent on the action of mechanical forces

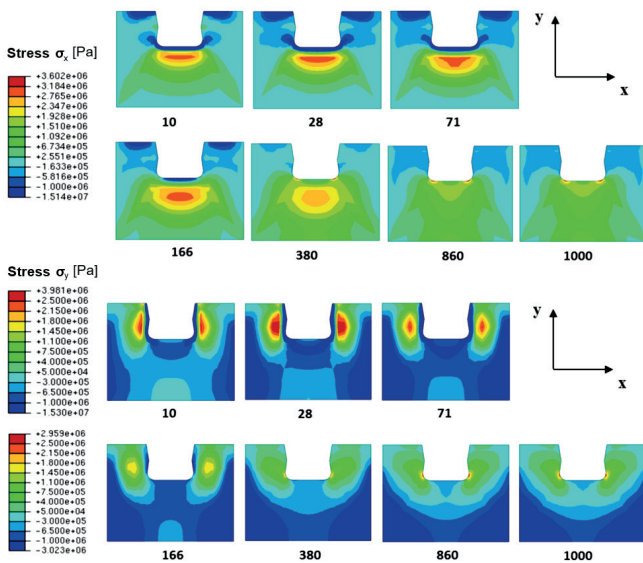

Fig. 6. Changes in stresses σ_x and σ_y at both ends of the carbon block caused by thermal shock operating in a time interval of 10 to 1000 seconds since the instant of filling the shaped groove with cast iron

While maintaining the division and numbering of separate sections according to Fig. 4, it has been observed that in beam no. “3” the stress distribution (Fig. 6) is similar to that which occurs during free deflection of the beam under the influence of heat. In this beam, the zones of compression, tension and compression are arranged perpendicular to the direction of heat flow. The same situation occurs when the state of stress σ_y is examined in beams nos. “1 and “2”. The combined effect of both stresses σ_x and σ_y can cause angular cracks. In turn, the σ_z stress, acting in direction parallel to the major axis of a carbon block, is responsible for the possible initiation of edge cracks.

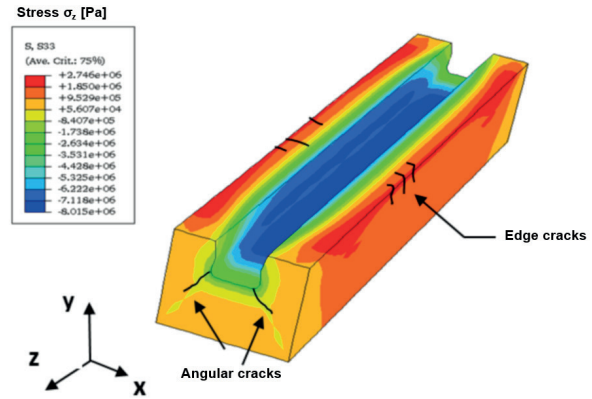

Fig. 7. Field of stress σ_z that occurs in carbon block after the lapse of 380 seconds since the time instant of filling the shaped groove with cast iron

Stresses in places where cracks occur reach the peak value at different time instants (Fig. 8).

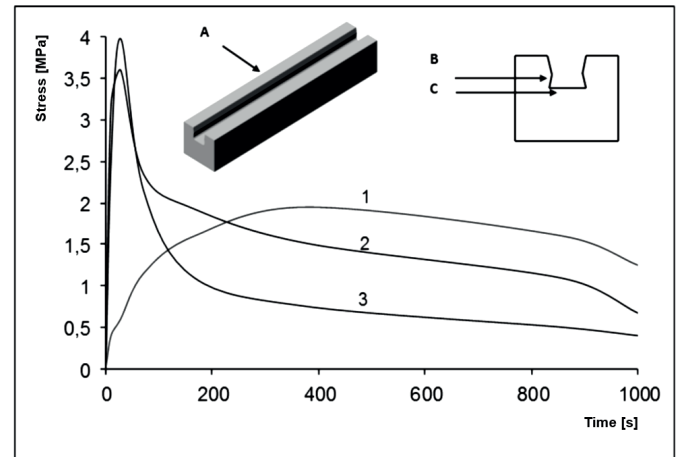

Fig. 8. The numerically determined, time-related, changes of stress in the areas of cracks formed in carbon block; 1 – stress σ_z in the area of edge cracks (A), 2 – stress σ_y in the area of angular cracks (B), 3 – stress σ_x in the area of angular cracks (C)

The maximum value of tensile stresses in the area of angular cracks is 4 MPa. This is the value close to the tensile strength of an amorphous carbon material, but it should be remembered that the area where it occurs is not directly adherent to the surface of the shaped groove, which is dominated by compressive stresses. Hence it can be concluded that angular cracks are initiated by the locally exceeded compressive strength of carbon material, while further propagation of cracks or arresting of their development depends on the state of stress in the zone slightly remote from the surface of the shaped groove. Stresses in the area of edge cracks reach a peak after the lapse of about 350 seconds since the time instant of filling the shaped groove with cast iron, their highest value being approximately 2 MPa. Calculations show that pouring of the groove with cast iron leaves a technological “trace” in the form of a map of the section own stresses occurring with certain regularity or, in extreme cases, cracks of various sizes. Onto this map is superimposed the map of performance stresses causing either development or closing of cracks already existing in the block.

6. Validation of numerical model

Studies have assumed that validity of the results derived from a numerical model will be checked by measurements of the steel pin deflection during the operation of cast iron pouring and cooling in the shaped groove. Measurements were repeated several times stating differences in the obtained values of displacement. Changes in the pin displacement defined by curves 1 and 2 (Fig. 9) represent the maximum and minimum measured values.

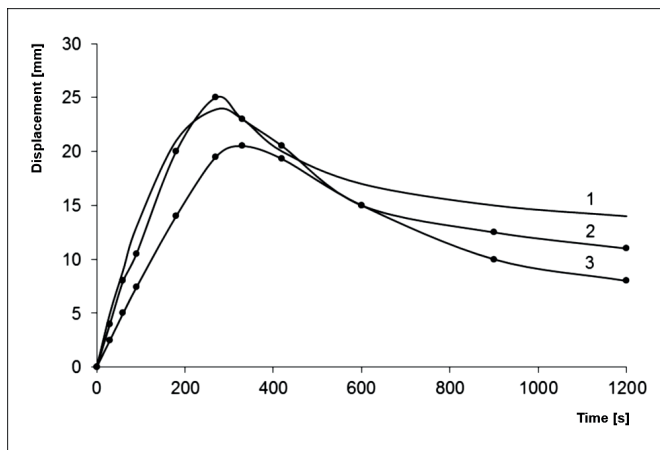

Fig. 9. Changes in the pin displacement during cooling of cast iron in the shaped groove forming part of carbon block; 1 – the values calculated numerically, 2 – the maximum measured displacement, 3 – the minimum measured displacement

Three methods of pouring are used most frequently:

- direct pouring from a ladle into the shaped groove of carbon block,
- pouring with the use of pouring basin acting at the same time as a spray gating system,
- pouring in segments according to a certain pattern.

In all these cases, the metal is fed into a space between the block and the pin. The deflection of the pin (Fig. 9) was measured during direct pouring of cast iron into the shaped groove. In this technique of pouring, the hot metal is heating most strongly the lower part of the pin and its side walls as the cast iron column is rising filling the free space in the groove. The upper surface of the pin has the lowest temperature, which makes its ends curve up. The deflection causes the formation of a gap between the end parts of the block and the pin, resulting in an increase of the electrical resistance. It can also induce a mechanical action of pin on the side walls of a carbon block and, consequently, lead to the formation of angular cracks.

Summary

Due to the high strength and low electrical resistance of connection, the most common method used for joining together the steel pin and the carbon block forming a cathode section is by pouring the free space in the groove with cast iron. However, both this operation and the contact between molten cast iron and the surface of the shaped groove give rise to the occurrence of thermal shock, which affects the carbon block and in some cases may result in its failure. Carbon materials well meet the requirements determined by the

physicochemical state generated in the process of electrolysis, but their polycrystalline structure, anisotropy and porosity are the reason why carbon blocks do not have a uniform strength distribution. Due to the high level of thermal stress, close to the strength limit of carbon material, deviations from the established technology of pouring or local reduction in the strength of material can initiate the formation of cracks. The complex thermal phenomena require detailed analysis of the temperature field and stress field formed in the section during the operation of connecting the pin with the block, and also during the start-up and operation of the cell. The state of stress in the carbon block is the sum of stresses induced by thermal shock and mechanical action of the pin movement. The results of numerical calculations were validated by trials and technological studies carried out in plants producing carbon electrodes and in a foundry of the aluminium smelting plant. A good agreement was found between the measured and calculated values of the displacement of a steel pin, which is the result of thermal shock produced by cast iron filling the shaped groove in a carbon block.

REFERENCES

- [1] M. Sorlie, H.A. Oye, *Cathodes in Aluminium Electrolysis*, Aluminim-Verlag GmbH, Duesseldorf, 2010.
- [2] B. Allard, D. Dumas, P. Lacroix, G. Fantozzi, D. Rouby, *Fracture behaviour of carbon materials for aluminium smelters*, *Light Metals* 749-758 (1991).
- [3] B. Larsen, M. Sorlie, *Stress analysis of cathode bottom blocks*, *Light Metals* 641-646 (1989).
- [4] I. Letizia, C. Bizzarri, M. Lezzerini, *How to improve the pig iron sealing of metallic bars*, *Light Metals* 1025-1036 (1985).
- [5] L. Michard, *Modelling of the sealing of cathode bars into carbon blocks*, *Light Metals* 2, 699-704 (1986).
- [6] J. Piekło, *Określenie kryteriów konstrukcyjnych dla połączenia stalowo-węglowego na przykładzie katody elektrolizera aluminium*, PhD thesis, AGH, Kraków 2002.
- [7] B. Allard, J.M. Dreyfus, M. Lenclud, *Evolution of thermal, electrical and mechanical properties of graphitised cathode blocks for aluminium electrolysis cells with temperature*, *Light Metals* 641-645 (2004).
- [8] Z. Shi, J. Xu, B. Ren, Y. Ban, Z. Wang, *Tests of various graphitic cathode blocks material for 300 kA aluminium reduction cells*, *Light Metals* 849-852 (2007).
- [9] H. Oye, *ISO standarts for testing of cathode materials*, *Light Metals* 937-942 (2008).
- [10] A. Murchi, W. Chen, M. Tremblay, *Comparative characterization of graphitized and graphitic cathode blocks*, *Light Metals* 617-624 (2003).
- [11] Z. Orłoś, *Naprężenia cieplne*, PWN, p.107, Warszawa 1991.
- [12] J. Piekło, *Experimental Investigation of the Stress Changes Induced by Thermal Shock in the Selected Cross-Sections of Birefringent Models by Means of the Photoelastic and Thermovision Methods*, *Prace Instytutu Odlewnictwa* 2-3, 71-91 (1990).
- [13] J. Piekło, *Analiza odkształceń i naprężeń podczas krzepnięcia i stygnięcia odlewu na podstawie obliczeń numerycznych wykonanych z wykorzystaniem modułu MAgMAstress*, *Biuletyn Instytutu Odlewnictwa* 4, 25-31 (1999).

